



16-1/2" Floor Model Drill Press

(Model 17-965)

PART NO. A10351 - 03-31-05
Copyright © 2005 Delta Machinery



To learn more about DELTA MACHINERY
visit our website at: www.deltamachinery.com.

For Parts, Service, Warranty or other Assistance,

please call **1-800-223-7278** (In Canada call **1-800-463-3582**).

ESPAÑOL: PÁGINA 17

TABLE OF CONTENTS

IMPORTANT SAFETY INSTRUCTIONS	2
SAFETY GUIDELINES	3
GENERAL SAFETY RULES	4
ADDITIONAL SPECIFIC SAFETY RULES	5
FUNCTIONAL DESCRIPTION	8
CARTON CONTENTS	8
ASSEMBLY	9
OPERATION	10
TROUBLESHOOTING	15
MAINTENANCE	15
SERVICE	15
ACCESSORIES	15
WARRANTY	16
ESPAÑOL	17
SERVICE CENTER LOCATIONSback cover

IMPORTANT SAFETY INSTRUCTIONS

▲ WARNING Read and understand all warnings and operating instructions before using any tool or equipment. When using tools or equipment, basic safety precautions should always be followed to reduce the risk of personal injury. Improper operation, maintenance or modification of tools or equipment could result in serious injury and property damage. There are certain applications for which tools and equipment are designed. Delta Machinery strongly recommends that this product NOT be modified and/or used for any application other than for which it was designed.

If you have any questions relative to its application DO NOT use the product until you have written Delta Machinery and we have advised you.

Online contact form at www.deltamachinery.com

Postal Mail: Technical Service Manager
Delta Machinery
4825 Highway 45 North
Jackson, TN 38305

(IN CANADA: 505 SOUTHGATE DRIVE, GUELPH, ONTARIO N1H 6M7)

Information regarding the safe and proper operation of this tool is available from the following sources:

Power Tool Institute
1300 Sumner Avenue, Cleveland, OH 44115-2851
www.powertoolinstitute.org

National Safety Council
1121 Spring Lake Drive, Itasca, IL 60143-3201

American National Standards Institute, 25 West 43rd Street, 4 floor, New York, NY 10036 www.ansi.org
ANSI 01.1 Safety Requirements for Woodworking Machines, and

the U.S. Department of Labor regulations www.osha.gov

SAVE THESE INSTRUCTIONS!

SAFETY GUIDELINES - DEFINITIONS

It is important for you to read and understand this manual. The information it contains relates to protecting YOUR SAFETY and PREVENTING PROBLEMS. The symbols below are used to help you recognize this information.



- ▲ DANGER** Indicates an imminently hazardous situation which, if not avoided, will result in death or serious injury.
- ▲ WARNING** Indicates a potentially hazardous situation which, if not avoided, could result in death or serious injury.
- ▲ CAUTION** Indicates a potentially hazardous situation which, if not avoided, may result in minor or moderate injury.
- CAUTION** Used without the safety alert symbol indicates potentially hazardous situation which, if not avoided, may result in property damage.

CALIFORNIA PROPOSITION 65

▲ WARNING **SOME DUST CREATED BY POWER SANDING, SAWING, GRINDING, DRILLING, AND OTHER CONSTRUCTION ACTIVITIES** contains chemicals known to cause cancer, birth defects or other reproductive harm.

Some examples of these chemicals are:

- lead from lead-based paints,
- crystalline silica from bricks and cement and other masonry products, and
- arsenic and chromium from chemically-treated lumber.

Your risk from these exposures varies, depending on how often you do this type of work. To reduce your exposure to these chemicals: work in a well ventilated area, and work with approved safety equipment, always wear **NIOSH/OSHA** approved, properly fitting face mask or respirator when using such tools.

GENERAL SAFETY RULES



⚠ WARNING READ AND UNDERSTAND ALL WARNINGS AND OPERATING INSTRUCTIONS BEFORE USING THIS EQUIPMENT. Failure to follow all instructions listed below, may result in electric shock, fire, and/or serious personal injury or property damage.

IMPORTANT SAFETY INSTRUCTIONS

- FOR YOUR OWN SAFETY, READ THE INSTRUCTION MANUAL BEFORE OPERATING THE MACHINE.** Learning the machine's application, limitations, and specific hazards will greatly minimize the possibility of accidents and injury.
- WEAR EYE AND HEARING PROTECTION. ALWAYS USE SAFETY GLASSES.** Everyday eyeglasses are NOT safety glasses. USE CERTIFIED SAFETY EQUIPMENT. Eye protection equipment should comply with ANSI Z87.1 standards. Hearing equipment should comply with ANSI S3.19 standards.
- WEAR PROPER APPAREL.** Do not wear loose clothing, gloves, neckties, rings, bracelets, or other jewelry which may get caught in moving parts. Nonslip footwear is recommended. Wear protective hair covering to contain long hair.
- DO NOT USE THE MACHINE IN A DANGEROUS ENVIRONMENT.** The use of power tools in damp or wet locations or in rain can cause shock or electrocution. Keep your work area well-lit to prevent tripping or placing arms, hands, and fingers in danger.
- MAINTAIN ALL TOOLS AND MACHINES IN PEAK CONDITION.** Keep tools sharp and clean for best and safest performance. Follow instructions for lubricating and changing accessories. Poorly maintained tools and machines can further damage the tool or machine and/or cause injury.
- CHECK FOR DAMAGED PARTS.** Before using the machine, check for any damaged parts. Check for alignment of moving parts, binding of moving parts, breakage of parts, and any other conditions that may affect its operation. A guard or any other part that is damaged **should be properly repaired or replaced.** Damaged parts can cause further damage to the machine and/or injury.
- KEEP THE WORK AREA CLEAN.** Cluttered areas and benches invite accidents.
- KEEP CHILDREN AND VISITORS AWAY.** Your shop is a potentially dangerous environment. Children and visitors can be injured.
- REDUCE THE RISK OF UNINTENTIONAL STARTING.** Make sure that the switch is in the "OFF" position before plugging in the power cord. In the event of a power failure, move the switch to the "OFF" position. An accidental start-up can cause injury.
- USE THE GUARDS.** Check to see that all guards are in place, secured, and working correctly to reduce the risk of injury.
- REMOVE ADJUSTING KEYS AND WRENCHES BEFORE STARTING THE MACHINE.** Tools, scrap pieces, and other debris can be thrown at high speed, causing injury.
- USE THE RIGHT MACHINE.** Don't force a machine or an attachment to do a job for which it was not designed. Damage to the machine and/or injury may result.
- USE RECOMMENDED ACCESSORIES.** The use of accessories and attachments not recommended by Delta may cause damage to the machine or injury to the user.
- USE THE PROPER EXTENSION CORD.** Make sure your extension cord is in good condition. When using an extension cord, be sure to use one heavy enough to carry the current your product will draw. An undersized cord will cause a drop in line voltage, resulting in loss of power and overheating. See the Extension Cord Chart for the correct size depending on the cord length and nameplate ampere rating. If in doubt, use the next heavier gauge. The smaller the gauge number, the heavier the cord.
- SECURE THE WORKPIECE.** Use clamps or a vise to hold the workpiece when practical. Loss of control of a workpiece can cause injury.
- FEED THE WORKPIECE AGAINST THE DIRECTION OF THE ROTATION OF THE BLADE, CUTTER, OR ABRASIVE SURFACE.** Feeding it from the other direction will cause the workpiece to be thrown out at high speed.
- DON'T FORCE THE WORKPIECE ON THE MACHINE.** Damage to the machine and/or injury may result.
- DON'T OVERREACH.** Loss of balance can make you fall into a working machine, causing injury.
- NEVER STAND ON THE MACHINE.** Injury could occur if the tool tips, or if you accidentally contact the cutting tool.
- NEVER LEAVE THE MACHINE RUNNING UNATTENDED. TURN THE POWER OFF.** Don't leave the machine until it comes to a complete stop. A child or visitor could be injured.
- TURN THE MACHINE "OFF", AND DISCONNECT THE MACHINE FROM THE POWER SOURCE** before installing or removing accessories, before adjusting or changing set-ups, or when making repairs. An accidental start-up can cause injury.
- MAKE YOUR WORKSHOP CHILDPROOF WITH PADLOCKS, MASTER SWITCHES, OR BY REMOVING STARTER KEYS.** The accidental start-up of a machine by a child or visitor could cause injury.
- STAY ALERT, WATCH WHAT YOU ARE DOING, AND USE COMMON SENSE. DO NOT USE THE MACHINE WHEN YOU ARE TIRED OR UNDER THE INFLUENCE OF DRUGS, ALCOHOL, OR MEDICATION.** A moment of inattention while operating power tools may result in injury.
- ⚠ WARNING** USE OF THIS TOOL CAN GENERATE AND DISBURSE DUST OR OTHER AIRBORNE PARTICLES, INCLUDING WOOD DUST, CRYSTALLINE SILICA DUST AND ASBESTOS DUST. Direct particles away from face and body. Always operate tool in well ventilated area and provide for proper dust removal. Use dust collection system wherever possible. Exposure to the dust may cause serious and permanent respiratory or other injury, including silicosis (a serious lung disease), cancer, and death. Avoid breathing the dust, and avoid prolonged contact with dust. Allowing dust to get into your mouth or eyes, or lay on your skin may promote absorption of harmful material. Always use properly fitting NIOSH/OSHA approved respiratory protection appropriate for the dust exposure, and wash exposed areas with soap and water.

ADDITIONAL SPECIFIC SAFETY RULES



FAILURE TO FOLLOW THESE RULES MAY RESULT IN SERIOUS PERSONAL INJURY.

1. **DO NOT OPERATE THIS MACHINE** until it is completely assembled and installed according to the instructions. A machine incorrectly assembled can cause serious injury.
2. **OBTAIN ADVICE** from your supervisor, instructor, or another qualified person if you are not thoroughly familiar with the operation of this machine. Knowledge is safety.
3. **FOLLOW ALL WIRING CODES** and recommended electrical connections to prevent shock or electrocution.
4. **SECURE THE MACHINE TO A SUPPORTING SUR-FACE.** Vibration can cause the machine to slide, walk, or tip over.
5. **NEVER START THE MACHINE BEFORE CLEARING THE TABLE OF ALL OBJECTS** (tools, scrap pieces, etc.). Debris can be thrown at high speed.
6. **NEVER START THE MACHINE** with the drill bit, cutting tool, or sanding drum against the workpiece. Loss of control of the workpiece can cause serious injury.
7. **PROPERLY LOCK THE DRILL BIT, CUTTING TOOL, OR SANDING DRUM IN THE CHUCK** before operating this machine.
8. **REMOVE THE CHUCK KEY BEFORE STARTING THE MACHINE.** The chuck key can be thrown out at a high speed.
9. **TIGHTEN ALL LOCK HANDLES** before starting the machine. Loss of control of the workpiece can cause serious injury.
10. **USE ONLY DRILL BITS, CUTTING TOOLS, SANDING DRUMS, OR OTHER ACCESSORIES** with shank size recommended in your instruction manual. The wrong size accessory can cause damage to the machine and/or serious injury.
11. **USE ONLY DRILL BITS, CUTTING TOOLS, OR SANDING DRUMS** that are not damaged. Damaged items can cause malfunctions that lead to injuries.
12. **USE RECOMMENDED SPEEDS** for all operations. Other speeds may cause the machine to malfunction causing damage to the machine and/or serious injury.
13. **AVOID AWKWARD OPERATIONS AND HAND POSITIONS.** A sudden slip could cause a hand to move into the bit.
14. **KEEP ARMS, HANDS, AND FINGERS** away from the bit. Serious injury to the hand can occur.
15. **HOLD THE WORKPIECE FIRMLY AGAINST THE TABLE.** Do not attempt to drill a workpiece that does not have a flat surface against the table, or that is not secured by a vise. Prevent the workpiece from rotating by clamping it to the table or by securing it against the drill press column. Loss of control of the workpiece can cause serious injury.
16. **TURN THE MACHINE “OFF” AND WAIT FOR THE DRILL BIT, CUTTING TOOL, OR SANDING DRUM TO STOP TURNING** prior to cleaning the work area, removing debris, removing or securing work-piece, or changing the angle of the table. A moving drill bit, cutting tool, or sanding drum can cause serious injury.
17. **PROPERLY SUPPORT LONG OR WIDE** work-pieces. Loss of control of the workpiece can cause severe injury.
18. **NEVER PERFORM LAYOUT, ASSEMBLY OR SET-UP WORK** on the table/work area when the machine is running. Serious injury can result.
19. **TURN THE MACHINE “OFF”,** disconnect the machine from the power source, and clean the table/work area before leaving the machine. **LOCK THE SWITCH IN THE “OFF” POSITION** to prevent unauthorized use. Someone else might accidentally start the machine and cause serious injury to themselves.
20. **ADDITIONAL INFORMATION** regarding the safe and proper operation of power tools (i.e. a safety video) is available from the Power Tool Institute, 1300 Sumner Avenue, Cleveland, OH 44115-2851 (www.powertoolinstitute.com). Information is also available from the National Safety Council, 1121 Spring Lake Drive, Itasca, IL 60143-3201. Please refer to the American National Standards Institute ANSI 01.1 Safety Requirements for Woodworking Machines and the U.S. Department of Labor OSHA 1910.213 Regulations.

SAVE THESE INSTRUCTIONS.
Refer to them often and use them to instruct others.

POWER CONNECTIONS

A separate electrical circuit should be used for your machines. This circuit should not be less than #12 wire and should be protected with a 20 Amp time lag fuse. If an extension cord is used, use only 3-wire extension cords which have 3-prong grounding type plugs and matching receptacle which will accept the machine's plug. Before connecting the machine to the power line, make sure the switch (s) is in the "OFF" position and be sure that the electric current is of the same characteristics as indicated on the machine. All line connections should make good contact. Running on low voltage will damage the machine.

⚠ DANGER DO NOT EXPOSE THE MACHINE TO RAIN OR OPERATE THE MACHINE IN DAMP LOCATIONS.

MOTOR SPECIFICATIONS

Your machine is wired for 115 volt, 60 HZ alternating current. Before connecting the machine to the power source, make sure the switch is in the "OFF" position.

GROUNDING INSTRUCTIONS

⚠ DANGER THIS MACHINE MUST BE GROUNDED WHILE IN USE TO PROTECT THE OPERATOR FROM ELECTRIC SHOCK.

1. All grounded, cord-connected machines:

In the event of a malfunction or breakdown, grounding provides a path of least resistance for electric current to reduce the risk of electric shock. This machine is equipped with an electric cord having an equipment-grounding conductor and a grounding plug. The plug must be plugged into a matching outlet that is properly installed and grounded in accordance with all local codes and ordinances.

Do not modify the plug provided - if it will not fit the outlet, have the proper outlet installed by a qualified electrician.

Improper connection of the equipment-grounding conductor can result in risk of electric shock. The conductor with insulation having an outer surface that is green with or without yellow stripes is the equipment-grounding conductor. If repair or replacement of the electric cord or plug is necessary, do not connect the equipment-grounding conductor to a live terminal.

Check with a qualified electrician or service personnel if the grounding instructions are not completely understood, or if in doubt as to whether the machine is properly grounded.

Use only 3-wire extension cords that have 3-prong grounding type plugs and matching 3-conductor receptacles that accept the machine's plug, as shown in Fig. A.

Repair or replace damaged or worn cord immediately.

2. Grounded, cord-connected machines intended for use on a supply circuit having a nominal rating less than 150 volts:

If the machine is intended for use on a circuit that has an outlet that looks like the one illustrated in Fig. A, the machine will have a grounding plug that looks like the plug illustrated in Fig. A. A temporary adapter, which looks like the adapter illustrated in Fig. B, may be used to connect this plug to a matching 2-conductor receptacle as shown in Fig. B if a properly grounded outlet is not available. The temporary adapter should be used only until a properly grounded outlet can be installed by a qualified electrician. The green-colored rigid ear, lug, and the like, extending from the adapter must be connected to a permanent ground such as a properly grounded outlet box. Whenever the adapter is used, it must be held in place with a metal screw.

NOTE: In Canada, the use of a temporary adapter is not permitted by the Canadian Electric Code.

⚠ DANGER IN ALL CASES, MAKE CERTAIN THAT THE RECEPTACLE IN QUESTION IS PROPERLY GROUNDED. IF YOU ARE NOT SURE, HAVE A QUALIFIED ELECTRICIAN CHECK THE RECEPTACLE.

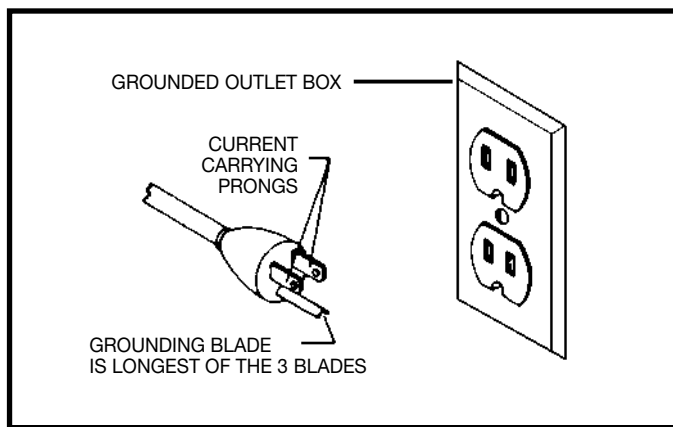

Fig. A

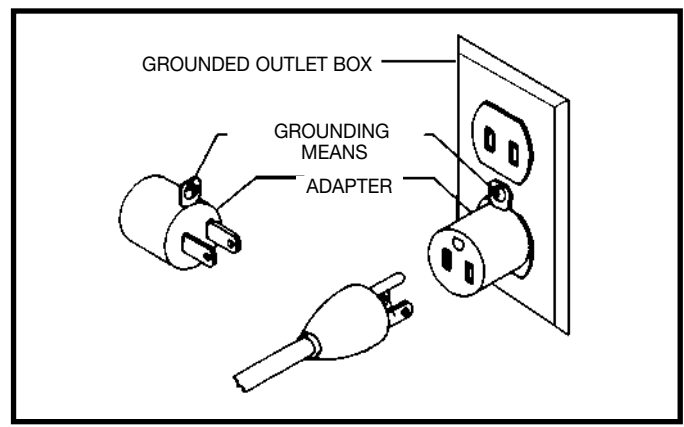

Fig. B

3. Grounded, cord-connected machines intended for use on a supply circuit having a nominal rating between 150 - 250 volts, inclusive:

You can have your drill press converted to 230 volt operation.

A qualified electrician must perform this conversion. Should you desire to have your drill press converted for 230 volt operation, take your drill press to your local Authorized Delta Service Center. You can call 800-223-7278 for the location of the nearest Authorized Service Center.

When converted for 230 volt operation, your drill press is intended for use on a circuit that has an outlet like the one illustrated in Fig. C. After conversion to 230 volts, the drill press will have a grounding plug that looks like the plug illustrated in Fig. C.

Make sure the drill press is connected to an outlet having the same configuration as the plug. No adapter is available or should be used when the drill press is converted for 230 volts. If the drill press must be reconnected for use on a different type of electrical circuit, the re-connection should be made by qualified service personnel; and after re-connection, the tool should comply with all local codes and ordinances.

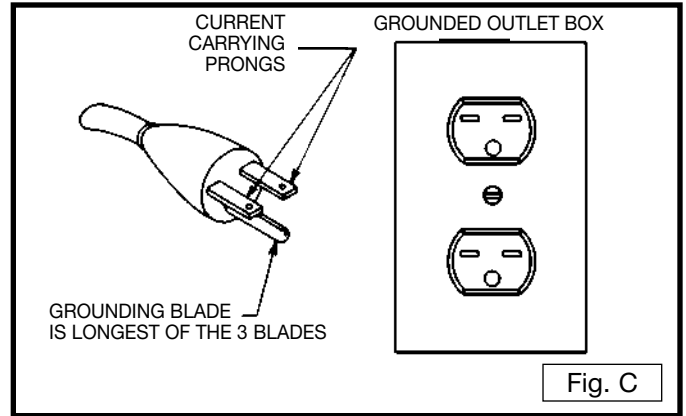

EXTENSION CORDS

⚠ WARNING Use proper extension cords. Make sure your extension cord is in good condition and is a 3-wire extension cord which has a 3-prong grounding type plug and matching receptacle which will accept the machine's plug. When using an extension cord, be sure to use one heavy enough to carry the current of the machine. An undersized cord will cause a drop in line voltage, resulting in loss of power and overheating. Fig. D-1 or D-2, shows the correct gauge to use depending on the cord length. If in doubt, use the next heavier gauge. The smaller the gauge number, the heavier the cord.

MINIMUM GAUGE EXTENSION CORD			
RECOMMENDED SIZES FOR USE WITH STATIONARY ELECTRIC MACHINES			
Ampere Rating	Volts	Total Length of Cord in Feet	Gauge of Extension Cord
0-6	120	up to 25	18 AWG
0-6	120	25-50	16 AWG
0-6	120	50-100	16 AWG
0-6	120	100-150	14 AWG
6-10	120	up to 25	18 AWG
6-10	120	25-50	16 AWG
6-10	120	50-100	14 AWG
6-10	120	100-150	12 AWG
10-12	120	up to 25	16 AWG
10-12	120	25-50	16 AWG
10-12	120	50-100	14 AWG
10-12	120	100-150	12 AWG
12-16	120	up to 25	14 AWG
12-16	120	25-50	12 AWG
12-16	120	GREATER THAN 50 FEET NOT RECOMMENDED	

Fig. D-1

MINIMUM GAUGE EXTENSION CORD			
RECOMMENDED SIZES FOR USE WITH STATIONARY ELECTRIC MACHINES			
Ampere Rating	Volts	Total Length of Cord in Feet	Gauge of Extension Cord
0-6	240	up to 50	18 AWG
0-6	240	50-100	16 AWG
0-6	240	100-200	16 AWG
0-6	240	200-300	14 AWG
6-10	240	up to 50	18 AWG
6-10	240	50-100	16 AWG
6-10	240	100-200	14 AWG
6-10	240	200-300	12 AWG
10-12	240	up to 50	16 AWG
10-12	240	50-100	16 AWG
10-12	240	100-200	14 AWG
10-12	240	200-300	12 AWG
12-16	240	up to 50	14 AWG
12-16	240	50-100	12 AWG
12-16	240	GREATER THAN 100 FEET NOT RECOMMENDED	

Fig. D-2

FUNCTIONAL DESCRIPTION

FOREWORD

The Delta Model 17-965 is a 16-1/2" floor model drill press. This heavy-duty machine has a 3/4 HP, 120/240V induction motor, 5/8" capacity chuck and key, cast iron table, rack and pinion elevation mechanism, and external depth stop. The 17-965 has a tilting table for angle drilling and side edges and parallel slots for fast workpiece clamping.

NOTICE: The photo on the manual cover illustrates the current production model. All other illustrations contained in the manual are representative only and may not depict the actual color, labeling, or accessories, and are intended to illustrate technique only.

CARTON CONTENTS

UNPACKING AND CLEANING

Carefully unpack the machine and all loose items from the shipping container(s). Remove the protective coating from all unpainted surfaces. This coating may be removed with a soft cloth moistened with kerosene (do not use acetone, gasoline or lacquer thinner for this purpose). After cleaning, cover the unpainted surfaces with a good quality household floor paste wax.

1. Drill Press Head
2. Column
3. Base
4. Table Bracket
5. Table
6. Chuck
7. Handles (3)
8. M8 x 125mm carriage head screws, flat washers, lockwashers, and hex nuts (2 ea.)
9. Locking lever for table bracket
10. Table locking lever
11. Table Adjusting Handle
12. 3mm Hex Wrench
13. 5mm Hex Wrench
14. 7/16-14 x 1-3/4" Hex Head Screws (4)
15. Chuck Key

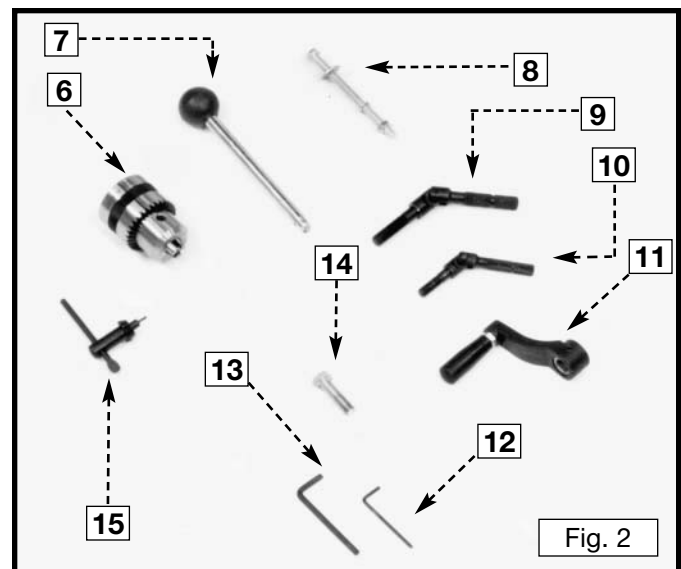
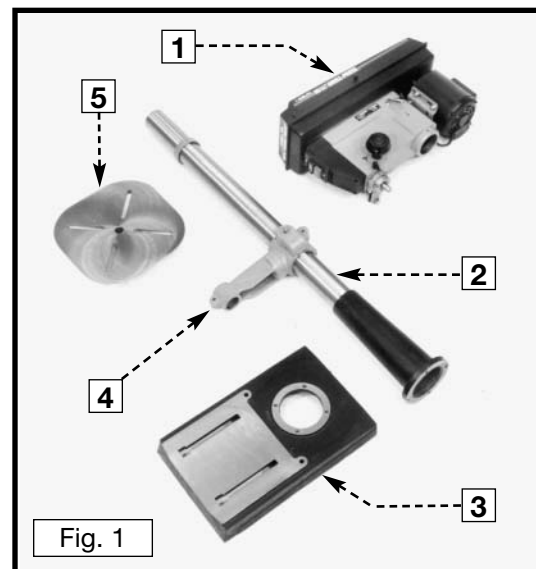

ASSEMBLY

ASSEMBLY TOOLS REQUIRED

3mm Hex Wrench (Supplied)

5mm Hex Wrench (Supplied)

Adjustable Wrench

ASSEMBLY TIME ESTIMATE

The assembly time for this unit is approximately 1-2 hours.

⚠ WARNING For your own safety, do not connect the machine to the power source until the machine is completely assembled and you read and understand the entire instruction manual.

1. Attach the column (A) Fig. 3 to the base (B) using the four 1-3/4" bolts (C), three of which are shown. Loosely thread the locking lever (D) into the table mounting bracket (E). Loosely thread the remaining locking lever (F) Fig. 4 into the split of the table mounting bracket (E).
2. Insert the table (G) Fig. 4 into the table mounting bracket (E) Fig. 3 and tighten the lever (D) Fig. 4 to lock the table in position. Tighten the locking lever (F) Fig. 4 to lock table-raising mechanism on the column.
3. Attach the table adjusting handle (H) Fig. 4 to the table mounting bracket (E).
4. Carefully position the drill press head (J) Fig. 5 on the column (A) as far as it will go. Align the drill press head (J) Fig. 5 and the table (G) Fig. 4 with the base of the drill press, and tighten the locking lever (K) and set screw (L) with the supplied hex wrench (M).

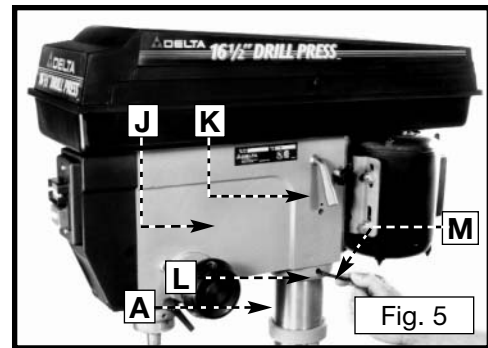
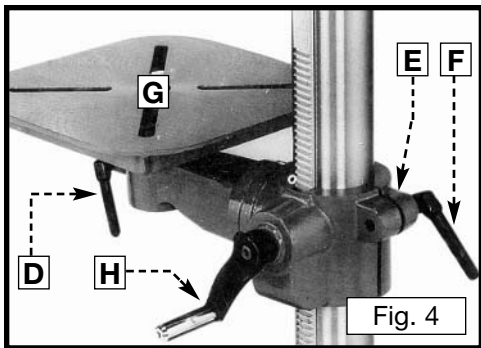
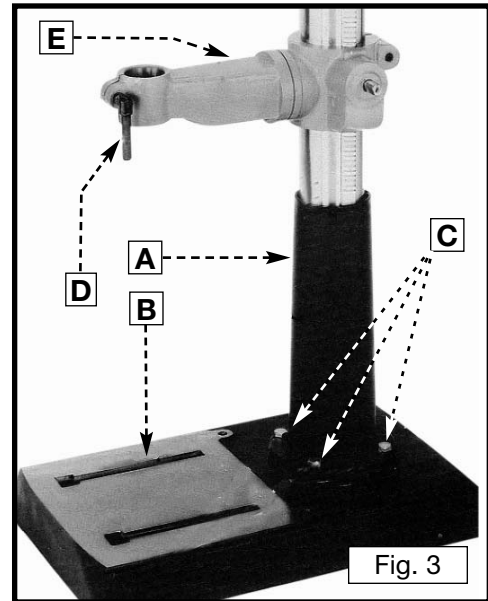

5. Thread the three pinion shaft handles (N) Fig. 6 into the three holes in the pinion shaft (P).
 6. **IMPORTANT:** Make certain the spindle (R) Fig. 7, and chuck (S) are free of any grease, lacquer or rust preventive coatings.
- NOTE:** If necessary, household oven cleaner can effectively remove these coatings from the spindle and chuck. Carefully follow the manufacturer's safety rules regarding its use.
7. Insert the chuck (S) Fig. 7 on the spindle (R) as far as it will go.

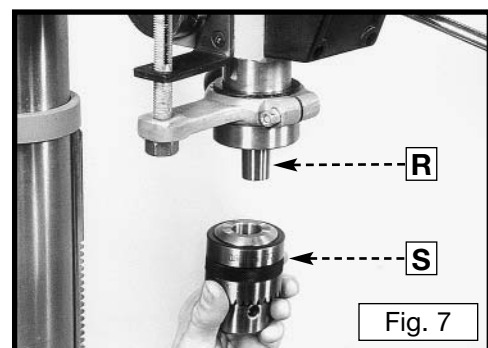
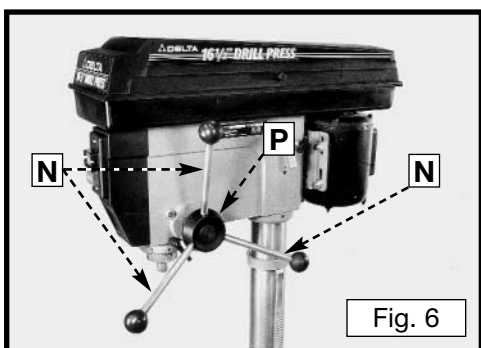

- Open the chuck jaws as wide as possible by turning chuck sleeve (T) Fig. 8. Hold the chuck (S) Fig. 8 and carefully drive and seat it (S) on the spindle with a rubber mallet or with a block of wood and hammer.

IMPORTANT: To avoid damage to the chuck, do not drive the chuck with a metal hammer.

- The drill press is shipped from the factory with the belts on the pulleys.

NOTE: Properly tension the belts before use. Refer to section “CHANGING SPINDLE SPEEDS AND ADJUSTING BELT TENSION”.

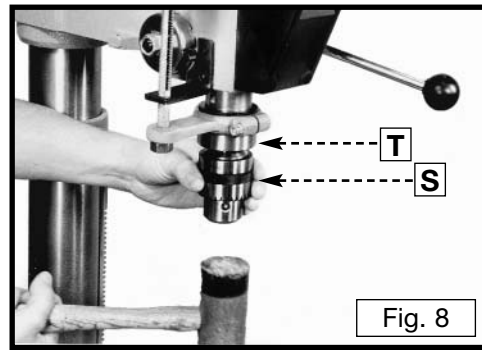

Fig. 8

MOUNTING DRILL PRESS ON A SUPPORTING SURFACE

If, during operation, the machine has a tendency to tip over, slide, or walk on the supporting surface, secure the machine base to the supporting surface with an M8x1.25x125mm carriage head screw, 8.5mm flat washer, 8.5mm lock washer, M8x1.25 hex nut through the two holes (S) Fig. 9 located in the machine base.

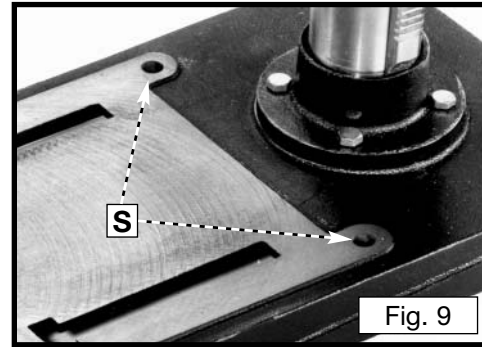

Fig. 9

MOUNTING THE DRILL PRESS ON A PLYWOOD BASE

If you do not fasten your machine permanently, then you must fasten the drill press to a plywood mounting board to prevent it from tipping over. Use a good grade of 3/4" or thicker plywood. **DO NOT** make the mounting board from particle board.

- Start with a 21" x 28" or larger piece of plywood. Drill two 3/8" diameter holes (B) Fig. 11 that match the mounting holes (S) Fig. 9 of the drill press base.
- Fasten the drill press base to the mounting board using the carriage bolts, flat washers, lockwashers, and hex nuts (C) Fig. 10, furnished with your drill press. The holes for the carriage bolt heads and flat washers under the board must be countersunk so that the bolt heads are flush or below the bottom surface of the board. Make sure to use a flat washer, lock washer and hex nut above the drill press base.
- The supporting board must extend a minimum of 3" beyond each edge of the drill press base (Fig. 11).
- Secure the plywood base to the floor or supporting surface if the drill press has any tendency to vibrate, slide, or walk during normal operation.

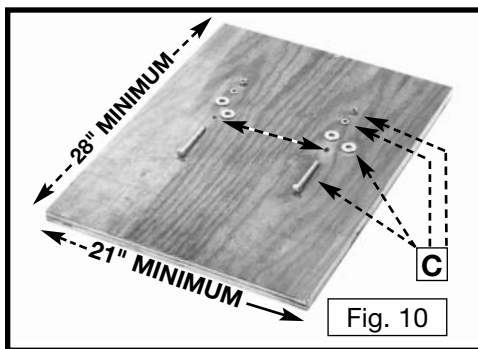

Fig. 10

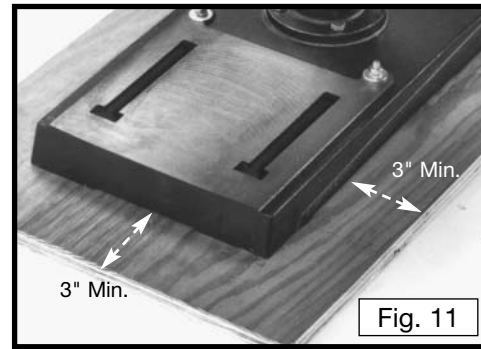

Fig. 11

OPERATION

OPERATIONAL CONTROLS AND ADJUSTMENTS

STARTING AND STOPPING THE DRILL PRESS

- The on/off switches (A and B) Fig. 12 are located on the front of the drill press. To turn the machine “ON”, depress the “ON” switch.
- To turn the machine “OFF”, depress the “OFF” switch.

⚠ WARNING Make sure that the switch is in the “OFF” position before plugging in the power cord. In the event of a power failure, depress the “OFF” switch. An accidental start-up can cause injury.

LOCKING SWITCH IN THE “OFF” POSITION

IMPORTANT: When the machine is not in use, the switch should be locked in the “OFF” position to prevent unauthorized use, using a padlock (C) Fig. 13 with a 3/16" diameter shackle.

▲ WARNING In the event of a power outage, always lock switch in “OFF” position until the main power is restored.

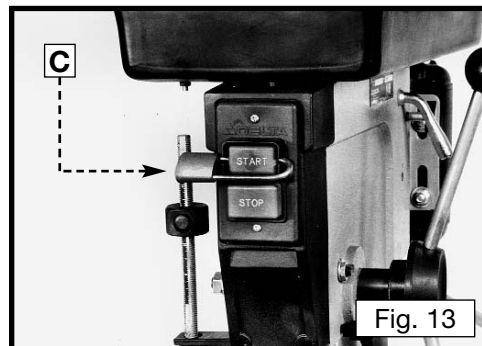
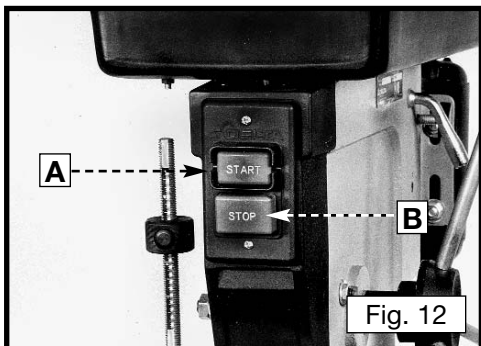

TABLE ADJUSTMENTS

1. To raise or lower the table (A) Fig. 14, loosen the table clamp handle (B) and rotate the raising/lowering handle (C). After the table is at the desired height, tighten the table clamp handle (B).

NOTE: Always raise (rather than lower) the table to the final position to allow the gears to mesh and prevent slippage.

2. To rotate the table (A) Fig. 14 on the table bracket, loosen the lock handle (D).
3. To tilt the table right or left, pull out and remove the table alignment pin (B) Fig. 15.

NOTE: If the pin (B) Fig. 15 is difficult to remove, turn the nut (A) clockwise to move the pin out of the casting.

4. The table alignment pin (A) Fig. 16 is shown removed. Loosen the table locking bolt (B) Fig. 16, tilt table to the desired angle and tighten the bolt (B). When you return the table to the level position, replace the table alignment pin (A) to automatically position the table surface 90 degrees to the spindle.
5. A tilt scale (A) and pointer (B) Fig. 17 are provided on the table bracket casting to indicate the degree of tilt.

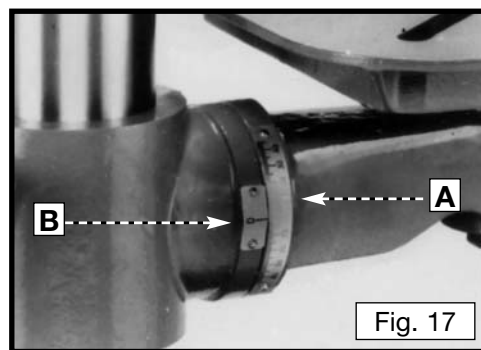
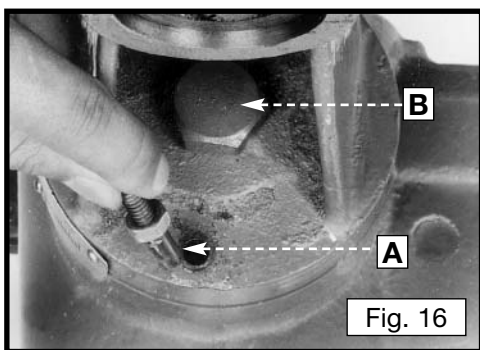
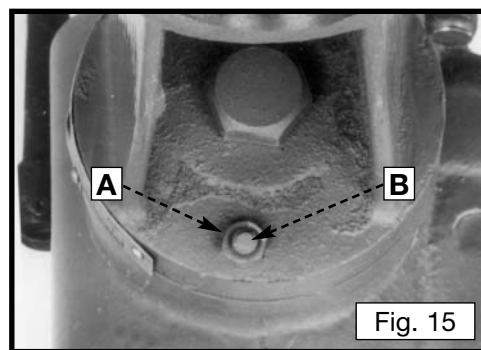
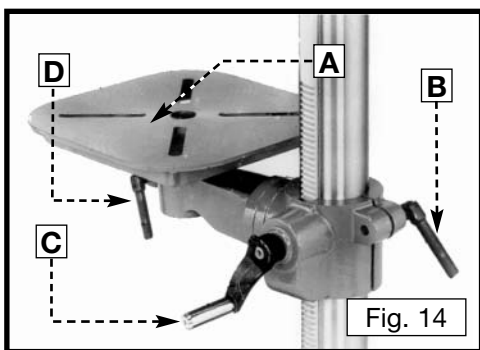

CHANGING SPEEDS AND ADJUSTING BELT TENSION

NOTE: Twelve spindle speeds are available on the drill press. A belt-positioning speed chart (E) Fig. 18 is located on the inside top cover of the drill press.

⚠ WARNING DISCONNECT MACHINE FROM POWER SOURCE.

1. Open the top cover (A) Fig. 18.
2. Loosen the lock-knob (B) Fig. 18 and the tension knob (located on the other side of the head casting) and move the tension lever (C) forward.
3. Position both belts (D) Fig. 18 on the desired steps of the spindle pulley, center pulley, and motor pulleys according to the chart.
4. After the belts are positioned, move the tension lever (C) Fig. 19 to the rear until the belts are properly tensioned.

NOTE: The belt should be just tight enough to prevent slipping. Excessive tension will reduce the life of the belt, pulleys, and bearings. Tension is correct when you can flex the belt (C) about 1" out of line, midway between the pulleys using light finger pressure.

5. Tighten the two tension lock knobs (B), one of which is shown.

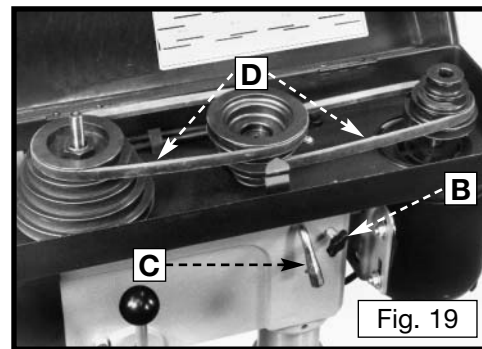
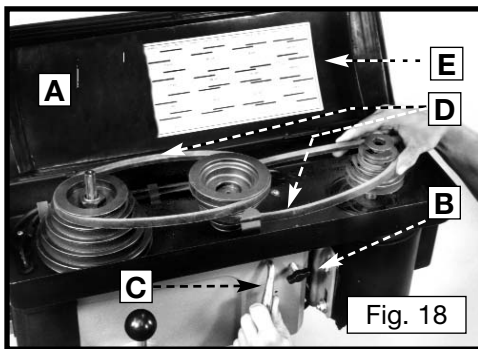

DRILLING HOLES TO DEPTH

When you want to drill a number of holes to the same depth, use the stop nut (A) Fig. 20 on the threaded stop rod (B).

⚠ WARNING DISCONNECT MACHINE FROM POWER SOURCE.

1. Insert the bit into the chuck.
2. Lower the chuck (C) Fig. 20, and the drill bit to your chosen depth by rotating the pinion shaft handles (D). Lock the quill in position by tightening the quill locking lever (E).

NOTE: The quill locking lever (E) is spring-loaded. Change it by pulling out on the handle and repositioning the hub of the handle on the nut located underneath the hub.

3. Depress the spring-loaded button (F) Fig. 20 and move the stop nut (A) until the bottom of the nut (A) contacts the stop (G). Loosen the quill locking-lever (E) to allow the chuck and drill bit to return to the up position.
4. Connect the machine to the power source and drill a test hole to check the adjustment. Readjust, if necessary, by rotating the stop nut (A) Fig. 20 for fine adjustment. You will not have to depress the button (F) while rotating the stop nut (A) for fine adjustment.

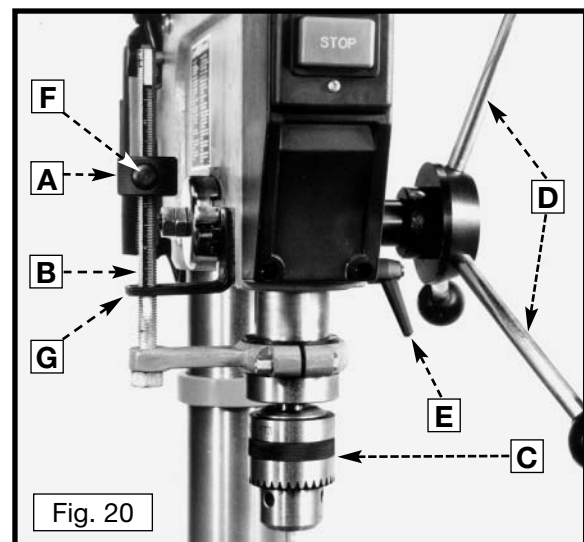

ADJUSTING THE SPINDLE RETURN SPRING

The spindle will automatically return slowly to its upper position when the handle is released. The spindle return spring was properly adjusted at the factory. However, to adjust, if necessary:

▲WARNING DISCONNECT MACHINE FROM POWER SOURCE.

1. Loosen the nuts (B) and (E) Fig. 21, but do not remove. Make sure that the spring housing (A) remains engaged with head casting (C).
2. While firmly holding the spring housing (A) Fig. 22, pull out the housing and rotate it (counter-clockwise to increase or clockwise to decrease the spring tension) until the boss (D) is engaged with the next notch on the housing. Tighten the two nuts (B) Fig. 22 to hold the housing in place

IMPORTANT: The inside nut (B) should not contact spring housing (A) when tightened.

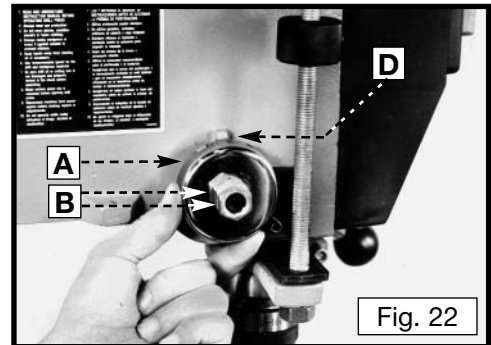
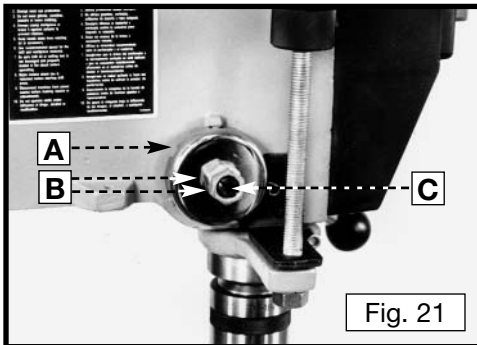

RAISING AND LOWERING THE SPINDLE

Raise and lower the spindle with the pinion handles (A) Fig. 23. You can lock the quill (B) Fig. 23 at any point in its travel by tightening locking lever (C).

NOTE: The quill locking lever (C) is spring-loaded. Pull outward on handle (C) and reposition it on the hub (D) of the handle.

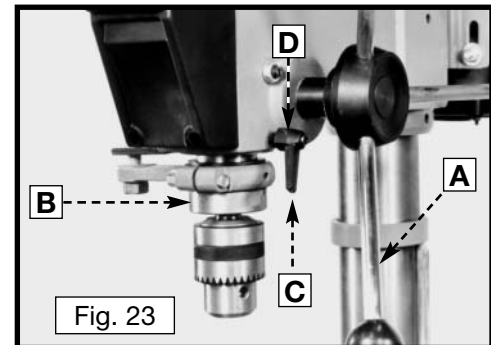

MACHINE USE

NOTE: Use drill bits with shank diameters of 5/8" or less.

NOTE: After installing a drill bit, use the supplied key to tighten all three locations on the chuck, two of which are shown at (A) Fig. 24.

▲WARNING The use of accessories and attachments not recommended by Delta may result in risk of injury.

IMPORTANT: When the workpiece (B) Fig. 24 is long enough, position it on the table with one end against the left side of the column (C) to prevent the workpiece from rotating. If it is not possible to support the workpiece against the column, clamp the workpiece to the table.

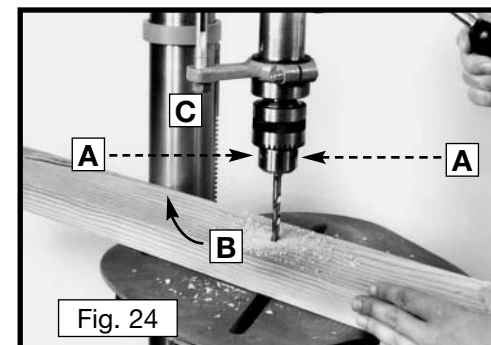

INSTALLING AND REMOVING DRILL BITS

NOTE: Use drill bits with a shank of 5/8" or less in diameter.

⚠ WARNING DISCONNECT MACHINE FROM POWER SOURCE.

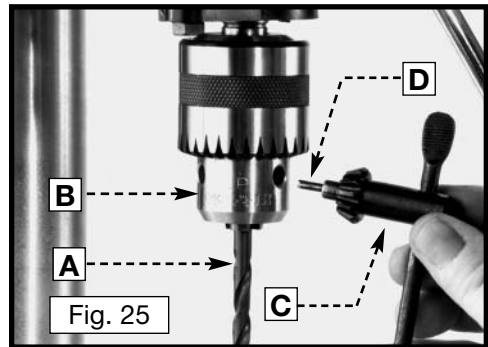

1. Insert the smooth end of drill bit (A) Fig. 25 in the chuck (B) as far as it will go, and then back the bit out 1/16" (or up to the flutes for small bits).
2. Center the drill bit (A) Fig. 25 in the chuck (B) before tightening the chuck with the key (C).
3. Turn the chuck key (C) Fig. 25 clockwise to tighten and counterclockwise to loosen the chuck jaws.
4. Tighten all three chuck jaws to secure the drill bit sufficiently to prevent slipping.
5. **Remove the chuck key (C) Fig. 25** from the chuck before starting the drill press. The chuck key (C) is equipped with a self-ejecting pin (D) which helps minimize the potential for the key to be left in the chuck.

CORRECT DRILLING SPEEDS

Factors that determine the correct speed are 1) the workpiece, 2) the size of the hole, 3) the type of bit or other cutter, and 4) the quality of cut.

⚠ WARNING Use the recommended speed for the drill press bit and workpiece.

DRILLING WOOD

Twist drills, usually intended for metal drilling, can also be used for boring holes in wood. However, machine spur bits are generally preferred for working in wood. These bits cut a flat bottom hole and are designed for removal of wood chips. Do not use hand bits which have a screw tip. At drill press speeds, they will lift and rotate the workpiece.

For through boring, align the workpiece so that the bit will go through the center hole in the table. Scribe a vertical line on the front of the column and a matching mark on the table bracket and the drill press head, so that the table and drill press head can be clamped in the center position at any height.

Feed the workpiece slowly when the bit is close to cutting through the wood to prevent splintering the bottom face. Use a scrap piece of wood as a base block under the work. This helps to reduce splintering and protects the point of the bit.

DRILLING METAL

Use clamps to hold the work when drilling metal. The workpiece should never be held in the bare hand. The drill bit may seize the work at any time, especially when breaking through the stock. If the piece is jerked out of your hand, you may be injured. The drill bit will be broken if the workpiece strikes the column.

Clamp the workpiece firmly while drilling. Any tilting, twisting, or shifting results not only in a rough hole, but also increases drill bit breakage. For flat work, lay the workpiece on a wooden base and clamp it firmly against the table to prevent it from turning. If the workpiece is of irregular shape and cannot lay flat on the table, it should be securely blocked and clamped.

TROUBLESHOOTING

For assistance with your machine, visit our website at www.deltamachinery.com for a list of service centers or call the DELTA Machinery help line at 1-800-223-7278 (In Canada call 1-800-463-3582).

MAINTENANCE

KEEP MACHINE CLEAN

Periodically blow out all air passages with dry compressed air. All plastic parts should be cleaned with a soft damp cloth. NEVER use solvents to clean plastic parts. They could possibly dissolve or otherwise damage the material.

⚠ WARNING Wear ANSI Z87.1 safety glasses while using compressed air.

FAILURE TO START

Should your machine fail to start, check to make sure the prongs on the cord plug are making good contact in the outlet. Also, check for blown fuses or open circuit breakers in the line.

LUBRICATION

Apply household floor paste wax to the machine table and extension table or other work surface weekly.

PROTECTING CAST IRON FROM RUST

To clean and protect cast iron tables from rust, you will need the following materials: 1 pushblock from a jointer, 1 sheet of medium Scotch-Brite™ Blending Hand Pad, 1 can of WD-40®, 1 can of degreaser, 1 can of TopCote® Aerosol. Apply the WD-40 and polish the table surface with the Scotch-Brite pad using the pushblock as a holddown. Degrease the table, then apply the TopCote® accordingly.

SERVICE



PARTS, SERVICE OR WARRANTY ASSISTANCE

All Delta Machines and accessories are manufactured to high quality standards and are serviced by a network of Porter-Cable • Delta Factory Service Centers and Delta Authorized Service Stations. To obtain additional information regarding your Delta quality product or to obtain parts, service, warranty assistance, or the location of the nearest service outlet, please call 1-800-223-7278 (In Canada call 1-800-463-3582).

ACCESSORIES

A complete line of accessories is available from your Delta Supplier, Porter-Cable • Delta Factory Service Centers, and Delta Authorized Service Stations. Please visit our Web Site www.deltamachinery.com for a catalog or for the name of your nearest supplier.

⚠ WARNING Since accessories other than those offered by Delta have not been tested with this product, use of such accessories could be hazardous. For safest operation, only Delta recommended accessories should be used with this product.

WARRANTY



Two Year Limited New Product Warranty

Delta will repair or replace, at its expense and at its option, any new Delta machine, machine part, or machine accessory which in normal use has proven to be defective in workmanship or material, provided that the customer returns the product prepaid to a Delta factory service center or authorized service station with proof of purchase of the product within two years and provides Delta with reasonable opportunity to verify the alleged defect by inspection. For all refurbished Delta product, the warranty period is 180 days. Delta may require that electric motors be returned prepaid to a motor manufacturer's authorized station for inspection and repair or replacement. Delta will not be responsible for any asserted defect which has resulted from normal wear, misuse, abuse or repair or alteration made or specifically authorized by anyone other than an authorized Delta service facility or representative. Under no circumstances will Delta be liable for incidental or consequential damages resulting from defective products. This warranty is Delta's sole warranty and sets forth the customer's exclusive remedy, with respect to defective products; all other warranties, express or implied, whether of merchantability, fitness for purpose, or otherwise, are expressly disclaimed by Delta.

PORTER-CABLE • DELTA SERVICE CENTERS (CENTROS DE SERVICIO DE PORTER-CABLE • DELTA)

Parts and Repair Service for Porter-Cable • Delta Machinery are Available at These Locations
(Obtenga Refaccion de Partes o Servicio para su Herramienta en los Siguientes Centros de Porter-Cable • Delta)

ARIZONA

Phoenix 85013-2906
4501 N. 7th Ave.
Phone: (602) 279-6414
Fax: (602) 279-5470

CALIFORNIA

Ontario 91761 (Los Angeles)
3949A East Guasti Road
Phone: (909) 390-5555
Fax: (909) 390-5554

San Diego 92111
7290 Clairemont Mesa Blvd.
Phone: (858) 279-2011
Fax: (858) 279-0362

San Leandro 94577 (Oakland)
3039 Teagarden Street
Phone: (510) 357-9762
Fax: (510) 357-7939

COLORADO

Denver 80223
700 West Mississippi Ave.
Phone: (303) 922-8325
Fax: (303) 922-0245

FLORIDA

Davie 33314 (Miami)
4343 South State Rd. 7 (441)
Unit #107
Phone: (954) 321-6635
Fax: (954) 321-6638

Tampa 33634
4909 West Waters Ave.
Phone: (813) 884-0434
Fax: (813) 888-5997

GEORGIA

Forest Park 30297 (Atlanta)
5442 Frontage Road,
Suite 112
Phone: (404) 608-0006
Fax: (404) 608-1123

ILLINOIS

Addison 60101 (Chicago)
400 South Rohlwing Rd.
Phone: (630) 424-8805
Fax: (630) 424-8895

Woodridge 60517 (Chicago)
2033 West 75th Street
Phone: (630) 910-9200
Fax: (630) 910-0360

KANSAS

Overland Park 66214
9201 Quivira Road
Phone: (913) 495-4330
Fax: (913) 495-4378

MARYLAND

Elkridge 21075 (Baltimore)
7397-102 Washington Blvd.
Phone: (410) 799-9394
Fax: (410) 799-9398

MASSACHUSETTS

Franklin 02038 (Boston)
Franklin Industrial Park
101E Constitution Blvd.
Phone: (508) 520-8802
Fax: (508) 528-8089

MICHIGAN

Madison Heights 48071 (Detroit)
30475 Stephenson Highway
Phone: (248) 597-5000
Fax: (248) 597-5004

MINNESOTA

Eden Prairie 55344
9709 Valley View Road
Phone: (952) 884-9191
Fax: (952) 884-3750

MISSOURI

St. Louis 63146
11477 Page Service Drive
Phone: (314) 997-9100
Fax: (314) 997-9183

NEW YORK

Flushing 11365-1595 (N.Y.C.)
175-25 Horace Harding Expwy.
Phone: (718) 225-2040
Fax: (718) 423-9619

NORTH CAROLINA

Charlotte 28270
9129 Monroe Road, Suite 115
Phone: (704) 841-1176
Fax: (704) 708-4625

OHIO

Columbus 43229
1948 Schrock Road
Phone: (614) 895-3112
Fax: (614) 895-3187

Cleveland 44125
8001 Sweet Valley Drive Unit #19
Phone: (216) 447-9030
Fax: (216) 447-3097

OREGON

Portland 97230
14811 North East Airport Way
Phone: (503) 255-6556
Fax: (503) 255-6543

PENNSYLVANIA

Willow Grove 19090
(Philadelphia)
520 North York Road
Phone: (215) 658-1430
Fax: (215) 658-1433

TEXAS

Carrollton 75006 (Dallas)
1300 Interstate 35 N, Suite 112
Phone: (972) 446-2996
Fax: (972) 446-8157

Houston 77022-2122

536 East Tidwell Rd.
Phone: (713) 692-7111
Fax: (713) 692-1107

WASHINGTON

Auburn 98001 (Seattle)
3320 West Valley HWY, North
Building D, Suite 111
Phone: (253) 333-8353
Fax: (253) 333-9613

Authorized Service Stations are located in many large cities. Telephone **800-438-2486** or **731-541-6042** for assistance locating one. Parts and accessories for Porter-Cable-Delta products should be obtained by contacting any Porter-Cable-Delta Distributor, Authorized Service Center, or Porter-Cable-Delta Factory Service Center. If you do not have access to any of these, call **800-223-7278** and you will be directed to the nearest Porter-Cable-Delta Factory Service Center. Las Estaciones de Servicio Autorizadas están ubicadas en muchas grandes ciudades. Llame al **800-438-2486** ó al **731-541-6042** para obtener asistencia a fin de localizar una. Las piezas y los accesorios para los productos Porter-Cable-Delta deben obtenerse poniéndose en contacto con cualquier distribuidor Porter-Cable-Delta, Centro de Servicio Autorizado o Centro de Servicio de Fábrica Porter-Cable-Delta. Si no tiene acceso a ninguna de estas opciones, llame al **800-223-7278** y le dirigirán al Centro de Servicio de Fábrica Porter-Cable-Delta más cercano.

CANADIAN PORTER-CABLE • DELTA SERVICE CENTERS

ALBERTA

Bay 6, 2520-23rd St. N.E.
Calgary, Alberta
T2E 8L2
Phone: (403) 735-6166
Fax: (403) 735-6144

BRITISH COLUMBIA

8520 Baxter Place
Burnaby, B.C.
V5A 4T8
Phone: (604) 420-0102
Fax: (604) 420-3522

MANITOBA

1699 Dublin Avenue
Winnipeg, Manitoba
R3H 0H2
Phone: (204) 633-9259
Fax: (204) 632-1976

ONTARIO

505 Southgate Drive
Guelph, Ontario
N1H 6M7
Phone: (519) 767-4132
Fax: (519) 767-4131

QUÉBEC

1515 ave.
St-Jean Baptiste, Suite 160
Québec, Québec
G2E 5E2
Phone: (418) 877-7112
Fax: (418) 877-7123

1447, Begin
St-Laurent, (Montréal),
Québec
H4R 1V8
Phone: (514) 336-8772
Fax: (514) 336-3505

The following are trademarks of PORTER-CABLE • DELTA (Las siguientes son marcas registradas de PORTER-CABLE • DELTA S.A.) (Les marques suivantes sont des marques de fabricant de la PORTER-CABLE • DELTA): Auto-Set®, BAMMER®, B.O.S.S.®, Builder's Saw®, Contractor's Saw®, Contractor's Saw II™, Delta®, DELTACRAFT®, DELTAGRAM™, Delta Series 2000™, DURATRONIC™, Emc²™, FLEX®, Flying Chips™, FRAME SAW®, Grip Vac™, Homecraft®, INNOVATION THAT WORKS®, Jet-Lock®, JETSTREAM®, 'kickstand', LASERLOC®, MICRO-SET®, Micro-Set®, MIDI LATHE®, MORTEN™, NETWORK™, OMNIJIG®, POCKET CUTTER®, PORTA-BAND®, PORTA-PLANE®, PORTER-CABLE®&(design), PORTER-CABLE®PROFESSIONAL POWER TOOLS, PORTER-CABLE REDEFINING PERFORMANCE™, Posi-Matic®, Q-3®&(design), QUICKSAND®&(design), QUICKSET™, QUICKSET II®, QUICKSET PLUS™, RIPTIDE™&(design), SAFE GUARD II®, SAFE-LOC®, Sanding Center®, SANDTRAP®&(design), SAW BOSS®, Sawbuck™, Sidekick®, SPEED-BLOC®, SPEEDMATIC®, SPEEDTRONIC®, STAIR EASE®, The American Woodshop®&(design), The Lumber Company®&(design), THE PROFESSIONAL EDGE®, THE PROFESSIONAL SELECT®, THIN-LINE™, TIGER®, TIGER CUB®, TIGER SAW®, TORQBUSTER®, TORQ-BUSTER®, TRU-MATCH™, TWIN-LITE®, UNIGUARD®, Unifence®, UNIFEEDER™, Unihead®, Uniplane™, Unirip®, Unisaw®, Univise®, Versa-Feeder®, VERSA-PLANE®, WHISPER SERIES®, WOODWORKER'S CHOICE™.

Trademarks noted with ™ and ® are registered in the United States Patent and Trademark Office and may also be registered in other countries. Las Marcas Registradas con el signo de ™ y ® son registradas por la Oficina de Registros y Patentes de los Estados Unidos y también pueden estar registradas en otros países.