

DREMEL® SCROLL SAW

owner's manual



WARNING

For your own safety
read your
Owner's Manual
before operating
your
Dremel
Scroll Saw

MODEL 1671 TYPE 2 SCROLL SAW
assembly • operation • safety instructions

DREMEL®

4915 - 21st Street | Racine, Wisconsin 53406, U.S.A.

For Your Safety . . .

▲WARNING READ ALL INSTRUCTIONS Failure to follow the safety rules listed below and other basic safety precautions may result in serious personal injury.

Work Area

- **KEEP WORK AREAS CLEAN.** Cluttered areas and benches invite accidents.
- **AVOID DANGEROUS ENVIRONMENTS.** Don't use power tools in damp or wet locations. Keep work area well lit. Do not expose power tools to rain. Do not use tool in presence of flammable liquids or gases.
- **KEEP CHILDREN AWAY.** Do not let visitors contact tool or extension cord. All visitors should be kept away from work area.
- **MAKE WORKSHOP CHILD-PROOF**—with padlocks, master switches, or by removing starter keys.

Personal Safety

- **STAY ALERT.** Watch what you are doing. Use common sense. Do not operate tool when you are tired.
- **KEEP GUARDS IN PLACE,** in working order, and in proper adjustment and alignment.
- **DON'T OVERREACH.** Keep proper footing and balance at all times.
- **DISCONNECT TOOLS.** When not in use; before servicing; when changing blades, bits, cutters, etc.
- **REMOVE ADJUSTING KEYS AND WRENCHES.** Form habit of checking to see that keys and adjusting wrenches are removed from tool before turning it on.
- **NEVER STAND ON TOOL.** Serious injury could occur if the tool is tipped or if the cutting tool is accidentally contacted.
- **AVOID ACCIDENTAL STARTING.** Don't carry plugged-in tool with finger on switch. Be sure switch is OFF when plugged in.
- **USE RECOMMENDED ACCESSORIES.** Consult the owner's manual for recommended accessories. Follow the instructions that accompany the accessories. The use of improper accessories may cause hazards.
- **DRESS PROPERLY.** Do not wear loose clothing or jewelry. They can be caught in moving parts. Rubber gloves and non-skid footwear are recommended when working outdoors. Wear protective hair covering to contain long hair.
- **ALWAYS USE SAFETY GLASSES.** Also use face or dust mask if cutting operation is dusty. Everyday eyeglasses only have impact resistant lenses; they are not safety glasses.

▲WARNING All repairs, electrical or mechanical, should be attempted only by trained repairmen. Contact the nearest Dremel Service Center, or Authorized Dremel Service Station or other competent repair service. Use only Dremel replacement parts; any other may create a hazard.

- **CHECK DAMAGED PARTS.** Before further use of the tool, a guard or other part that is damaged should be carefully checked to determine that it will operate properly and perform its intended function. Check for alignment of moving parts, binding of moving parts, breakage of parts, mounting, and any other conditions that may affect its operation. A guard or other part that is damaged should be properly repaired or replaced. Have defective switches replaced. Do not use tool if switch does not turn it on or off.

Tool Use

- **DON'T FORCE TOOL.** It will do the job better and safer at the rate for which it was designed.
- **USE THE RIGHT TOOL.** Don't force small tool or attachment to do the job of a heavy-duty tool. Don't use tool for purpose not intended—for example; don't use circular saw for cutting tree limbs or logs.
- **SECURE WORK.** Use clamps or a vise to hold work. It's safer than using your hand and it frees both hands to operate the tool.
- **DIRECTION OF FEED.** Feed work into a blade or cutter against the direction of rotation of the blade or cutter only.
- **NEVER LEAVE TOOL RUNNING UNATTENDED.** Turn power off. Don't leave tool until it comes to a complete stop.

Tool Care

- **DO NOT ALTER OR MISUSE TOOL.** These tools are precision built. Any alteration or modification not specified is misuse and may result in a dangerous condition.
- **AVOID GASEOUS AREAS.** Do not operate electric tools in gaseous or explosive atmospheres. Motors in these tools normally spark, and the sparks might ignite fumes.
- **MAINTAIN TOOLS WITH CARE.** Keep tools sharp and clean for better and safer performance. Follow instructions for lubricating and changing accessories. Inspect tool cords periodically and if damaged, have repaired by authorized service facility. Inspect extension cords periodically and replace if damaged. Keep handles dry, clean and free from oil and grease.

▲WARNING Before connecting the tool to a power source (receptacle, outlet, etc.), be sure voltage supplied is the same as that specified on the nameplate of the tool. A power source with voltage greater than that specified for the tool can result in SERIOUS INJURY to the user, as well as damage to the tool. If in doubt, DO NOT PLUG IN THE TOOL. Using a power source with voltage less than the nameplate rating is harmful to the motor.

"SAVE THESE INSTRUCTIONS"

Tool Safety Rules

- **⚠ WARNING** For your own safety, do not attempt to operate your scroll saw until it is completely assembled and installed according to the instructions . . . and until you read and understand the following:

- GENERAL SAFETY RULES See Page 2
- TOOL RULES See Page 3
- GETTING TO KNOW YOUR SAW See Page 5
- OPERATIONS See Page 10
- ADJUSTMENTS See Pages 6, 7, 8
- MAINTENANCE See Page 12

Stability of Saw

- Your scroll saw must be bolted securely to a stand or workbench. In addition, if there is any tendency for the scroll saw to tip over or move during certain operations, such as cutting long, heavy boards, bolt your scroll saw stand or workbench to the floor.

Location

- This scroll saw is intended for indoor use only.

Protection: Eyes, Hands, Face, Ears, Body

- Wear safety goggles and a face shield if operation is dusty. Wear ear plugs or muffs during extended periods of operation. Do not wear gloves . . . roll long sleeves above the elbow.
- Do not cut pieces of material too small to hold by hand. **HINT:** When making a very small cutout, always secure the workpiece to a scrap piece of plywood with double-faced tape. This way, the work is supported and your fingers are away from the blade.
- Avoid awkward hand positions where a sudden slip could cause a hand to move into the blade.
- Never turn your scroll saw on before clearing the table of all objects (tools, scraps of wood, etc.) except for the workpiece and related feed or support devices for the operation planned.
- ALWAYS adjust the drop foot and blade guard to just clear the workpiece to protect the operator, keep blade breakage to a minimum and provide maximum support for blade.
- Always adjust blade tension correctly.
- Make sure blade teeth run downward toward table.

- When cutting a large piece of material, make sure it is supported at table height.
- Hold the work firmly against the table.
- Do not feed the material too fast while cutting. Only feed the material fast enough so that the blade will cut. Keep fingers away from the blade.
- Use caution when cutting off material which is irregular in cross section — it could pinch the blade before the cut is completed. A piece of molding, for example, must lay flat on the table and not be permitted to rock while being cut.
- Use caution when cutting off round material such as dowel rods or tubing. They have a tendency to roll while being cut, causing the blade to "bite"
- Never leave the scroll saw running unattended. Turn the saw OFF, make sure the saw has come to a complete stop, and then remove plug from power supply before leaving the work area.
- Do not perform layout, assembly or setup work on the table while the cutting tool is operating.
- Turn saw off and remove plug from power supply outlet before installing or removing an accessory attachment.
- Should any part of this scroll saw be missing, bend or fail in any way, or any electrical component fail to perform properly, shut off power switch and remove plug from power supply outlet. Replace damaged, missing, and/or failed parts before resuming operation.

Think Safety

- Safety is a combination of operator common sense and alertness whenever the scroll saw is in operation.
- **⚠ WARNING** Do not allow familiarity (gained from frequent use of your scroll saw) to become carelessness. Always remember that a careless fraction of a second is sufficient to inflict severe injury.



The operation of any power tool can result in foreign objects being thrown into the eyes, which can result in severe eye damage. Always wear safety glasses or eye shields before commencing power tool operation. We recommend **Wide Vision Safety Mask** for use over spectacles or standard safety glasses.

Grounding Instructions

Grounded Tools With Three-Prong Plugs

⚠ WARNING Improper grounding can shock, burn or electrocute.

Grounding of this tool is necessary while in use to protect you from electric shock or electrocution. This tool is equipped with an approved three-conductor cord and three-prong grounding-type plug to fit the proper grounding-type receptacle. Do not remove grounding prong from the three prong grounding-type plug. The green (or green and yellow) conductor in the cord is the grounding wire. Never connect the green (or green and yellow) wire to a live terminal. Your unit is for use on less than 150 volts and it has a plug that looks like Fig. "A".

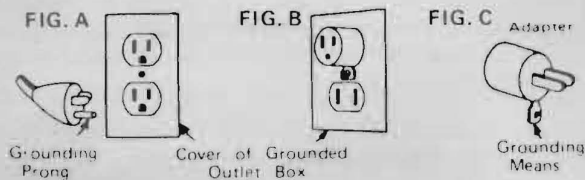

An adapter, Fig. "B" and "C" is available for connecting Fig. "A" plugs to two-prong receptacles. The green colored rigid ear, lug, etc., extending from the adapter must be connected to a permanent ground such as a properly grounded outlet box.

NOTE: The grounding adapter, Fig. "C" is prohibited in Canada by Canadian Electrical Code-Part 1. Therefore the instructions for its use are not applicable in Canada.

Extension Cords

⚠ WARNING Use of damaged cords can shock, burn or electrocute.

Replace damaged or worn cords immediately. The table shows the correct size to use, depending on cord length and nameplate amperage rating of tool. If in doubt, use the next heavier gauge. An undersized cord will cause a drop in line voltage, resulting in loss of power and over-heating. **NOTE:** The smaller the gauge number, the heavier the cord.

Use only three-wire extension cords with three-hole receptacles which accept the tool plug and have three-prong grounding-type plugs. Three-wire extension cords are available.

Recommended Minimum Gauge for Cord Extensions for Portable Electric Tools

Name Plate Amps.	Wire Gauge Chart A.W.G.				
	Cord Length in Feet				
	120V	25	50	100	150
3-6		18	16	16	14
6-8		18	16	14	12
8-10		18	16	14	12
10-12		16	16	14	12
12-16		14	12	Not Recommended	

Dremel Limited Warranty

Your Dremel product is warranted against defective material or workmanship for a period of one year from date of purchase. In the event of a failure of a product to conform to this written warranty, please take the following action:

- DO NOT return your product to the place of purchase.
- Carefully package the product by itself, with no other items, and return it freight prepaid, along with:
 - A copy of your dated proof of purchase (please keep a copy for yourself).
 - A written statement about the nature of the problem.
 - Your name, address and phone number to:

UNITED STATES

Dremel Service Center
4915 Twenty-First Street
Racine, Wisconsin 53406

OR

Dremel Service Center
4631 E. Sunny Dunes
Palm Springs, CA 92264

EASTERN CANADA

Giles Tool Agency
8520 Lawrence av. east,
Scarborough, Ont.
Canada M1C 4A7

OR

WESTERN CANADA
Totem Tools
3851 Main st.
Vancouver, B.C.
Canada V5V 3P1

We recommend that the package be insured against loss or damage in transit, for which we cannot be responsible.

This warranty applies only to the original registered purchaser. **DAMAGE TO THE PRODUCT RESULTING FROM TAMPERING,**

ACCIDENT, ABUSE, NEGLIGENCE, UNAUTHORIZED REPAIRS OR MODIFICATIONS, UNAPPROVED ATTACHMENTS OR OTHER CAUSES UNRELATED TO PROBLEMS WITH MATERIAL OR WORKMANSHIP ARE NOT COVERED BY THIS WARRANTY.

No employee, agent, dealer or other person is authorized to give any warranties on behalf of Dremel. If Dremel inspection shows that the problem was caused by problems with material or workmanship within the limitations of the warranty, Dremel will repair or replace the product free of charge and return product prepaid. Repairs made necessary by normal wear or abuse, or repair for product outside the warranty period, if they can be made, will be charged at regular factory prices.

DREMEL MAKES NO OTHER WARRANTY OF ANY KIND WHATSOEVER, EXPRESSED OR IMPLIED, AND ALL IMPLIED WARRANTIES OF MERCHANTABILITY AND FITNESS FOR A PARTICULAR PURPOSE WHICH EXCEED THE ABOVE MENTIONED OBLIGATION ARE HEREBY DISCLAIMED BY DREMEL AND EXCLUDED FROM THIS LIMITED WARRANTY.

This warranty gives you specific legal rights and you may also have other rights which vary from state to state. The obligation of the warrantor is solely to repair or replace the product. The warrantor is not liable for any incidental or consequential damages due to any such alleged defect. Some states do not allow the exclusion or limitations of incidental or consequential damages, so the above limitations or exclusion may not apply to you.

For prices and warranty fulfillment in the continental United States, contact your local Dremel distributor.

Getting to know your scroll saw

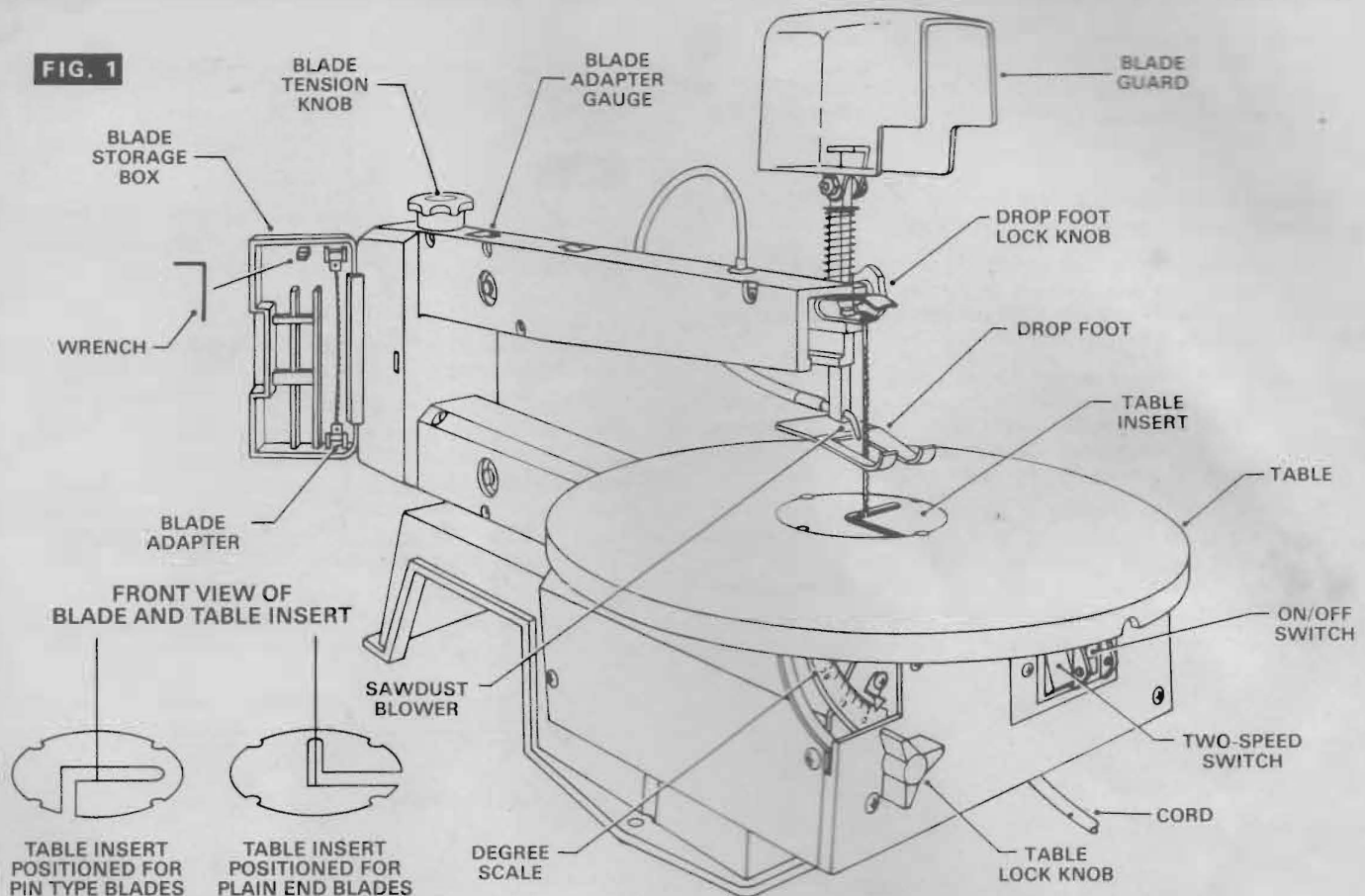

This versatile heavy-duty scroll saw is great for making toys, puzzles, games, fretwork, and jewelry, and because of its cutting capacity, is a handy do-it-yourself tool. It cuts wood up to 2 inches thick as well as plastics and metals.

BLADE STORAGE CASE . . . Your scroll saw is equipped with a blade storage area located on the side of the saw. The blade storage area conveniently stores the blade adapters, wrench and both pin and plain end blades.

SAWDUST BLOWER . . . Keeps workpiece clean for more accurate scroll cuts. For best results, always direct air flow from brass tube at blade and workpiece. To adjust, loosen set screw in the foot assembly, position tube and tighten screw. **CAUTION:** To prevent brass tube from collapsing **DO NOT OVERTIGHTEN.**

DROP FOOT . . . The foot should always be lowered until it just rests on top of the workpiece to prevent workpiece from lifting, but not so much that the workpiece drags.

DROP FOOT LOCK KNOB . . . Allows you to raise or lower the foot and lock it at desired heights.

BLADE GUARD . . . Should always be lowered over the blade during cutting operation.

BLADE TENSION KNOB . . . Allows you to loosen or tighten the blade tension by rotating the knob.

TABLE LOCK KNOB . . . Allows you to tilt the table and lock it at desired angle up to 45 degrees.

DEGREE SCALE . . . Shows the degree the table is tilted.

TWO-SPEED SWITCH . . . Your scroll saw is equipped with a high/low switch for greater versatility. To increase speed, push switch to high; to decrease speed, push switch to low. 890 SPM Low, 1790 SPM High.

ON/OFF SWITCH . . . Has holes provided by the switch for a lock (not included). **THIS FEATURE IS INTENDED TO PREVENT UNAUTHORIZED AND POSSIBLY HAZARDOUS USE BY CHILDREN AND OTHERS.** To turn saw on, push switch to the "on" position; to turn saw off, push switch to the "off" position.

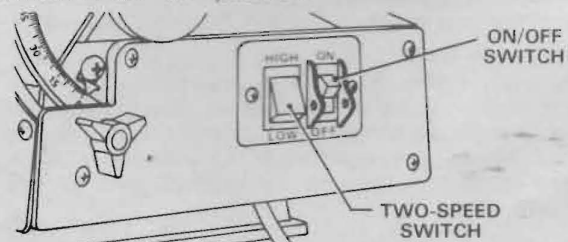

BLADE ADAPTER . . . Allows you to use plain end blades.

BLADE ADAPTER GAUGE . . . Used for attaching the blade adapters at the proper length for operation.

TABLE INSERT . . . Should always be in place and flush with table during cutting operation.

Adjustments

SETTING THE TABLE FOR HORIZONTAL OR BEVEL CUTTING

1. Loosen the table lock knob, and the saw table can be tilted to the left and locked at any angle from 0 degree horizontal cutting position up to 45 degrees for bevel cutting. (Fig 2).
2. A degree scale is also provided under the work table as a convenient reference for setting the approximate table angle for bevel cutting. When greater precision is required, make practice cuts and adjust the table as necessary for your requirements.
3. NOTE: When cutting at extreme angles, the drop foot should be lifted off the work piece, as it will impede cutting. Hold the work piece against the table. The drop foot may be disassembled when thick materials are cut at extreme angles.

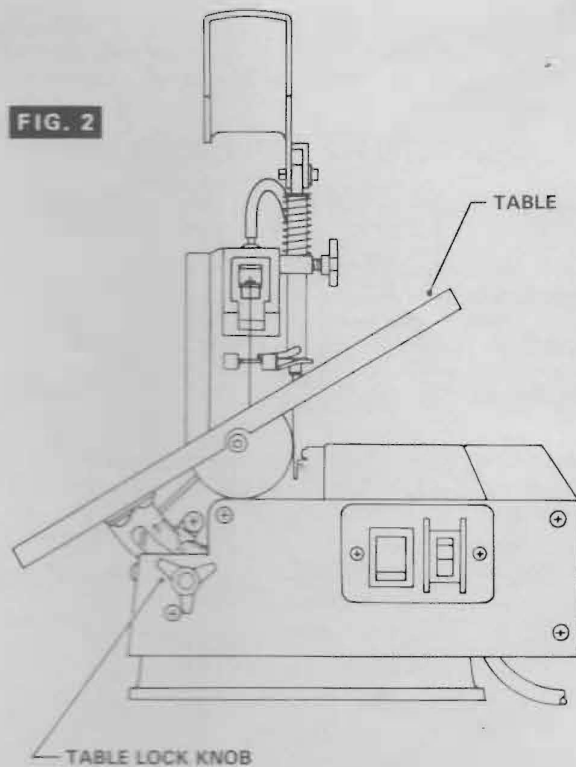

ALIGNING THE DEGREE SCALE POINTER

1. Loosen the table lock knob and move the table until it is approximately perpendicular, or at a right angle to the blade.
2. Place a small square on the table next to the blade as shown in (Fig. 3) to check if the table is 90 degrees to the blade. If adjustment is needed, raise or lower the table until table is approximately 90 degrees to the blade and securely tighten the table lock knob.
3. Loosen the screw holding the degree scale pointer, as shown in (Fig. 3), move pointer to the 0 degree mark and securely tighten screw. Remember, the degree scale is a convenient guide but should not be relied upon for precision. Make practice cuts in scrap wood to determine if your angle settings are correct.

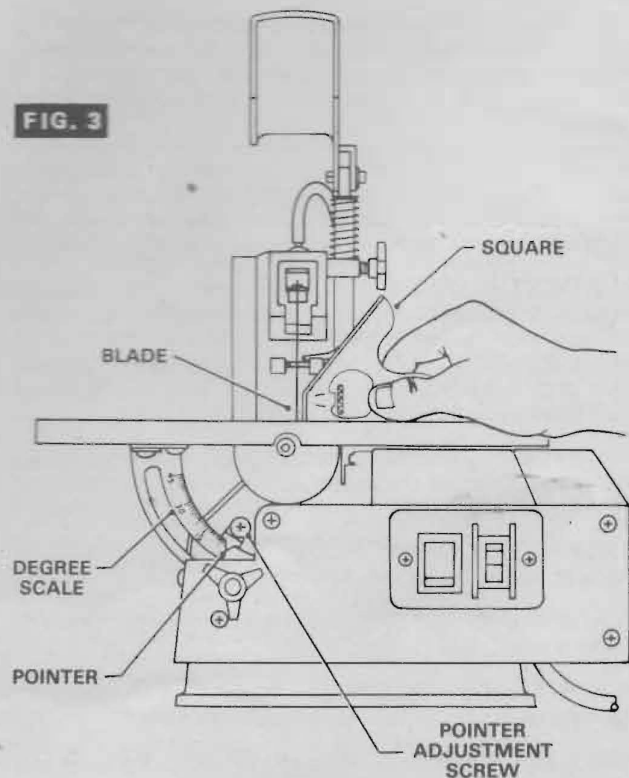

Removing and installing blades

BLADES

Your new scroll saw accepts 5 inch pin type blades. Your saw is also equipped with blade adapters that allow you to use a variety of 5 inch plain-end blades (See Accessories on page 11).

WARNING To prevent personal injury always disconnect the plug from power source before changing blades or making adjustments.

REMOVING AND INSTALLING (Pin Type Blades)

1. Rotate the blade tension knob counter-clockwise to release blade tension.
2. Remove table insert and remove blade from the inner upper and lower blade holders by pulling forward on blade and then lifting the blade through the access hole in the table. Slight downward pressure against the upper holder may be helpful when removing blade from upper holder.
3. Look at the blade holders closely and notice the blade slots and pin recesses in the blade holders. The blade holders are made so you can position the

blade for cutting from the front or from one side of the saw as shown in (Fig. 4). Cutting from the side of the saw will be necessary when your work piece exceeds 16 inches in length. It allows your scroll saw to cut like a band saw. For 0 degree horizontal cutting only.

4. In order to cut, and avoid uncontrollable lifting of the work piece, the teeth of the blade used on the scroll saw should always point downward as shown in (Fig. 4) when installed.
5. Install the blade by inserting one end of the blade through the access hole in the table and hook the blade pin in the pin recess in the inner lower blade holder. Slide the top blade pin into the pin recess of the inner upper blade holder. You may need to press down lightly on the upper blade holder to install the blade.
6. Carefully tighten the blade by rotating the blade tension knob clockwise just until you feel the slack in the blade removed. Double check to see that the pins are properly located in the blade holder. Then turn the blade tension knob ONE full turn clockwise. This amount of blade pressure should do well for most cutting operations and blades.

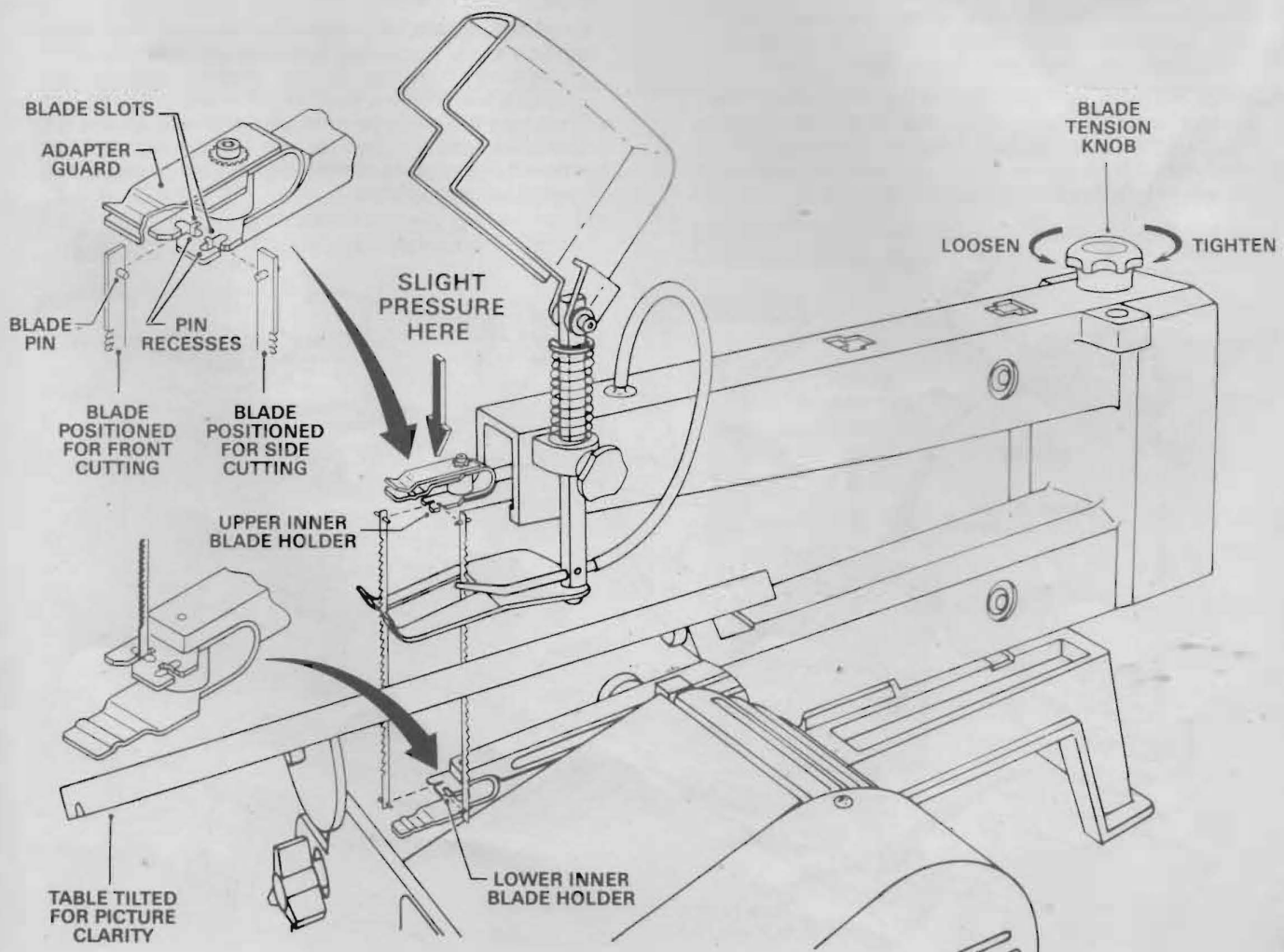

ATTACHING THE BLADE ADAPTERS TO PLAIN-END BLADES (Straight Cutting)

1. Adjust one set screw on each adapter until it covers approximately half the hole, as shown in (Fig. 5).
2. Loosen the other set screws just enough to slide one adapter onto each end of blade, flush with end of blade as shown in (Fig. 6). (If blade touches pin, it can't be attached to blade holder).
3. Place the blade and adapters into the gauge to set the blade to the proper length as shown in (Fig. 7), and securely tighten the other set screw with the wrench provided.

ATTACHING BLADE ADAPTERS TO PLAIN-END BLADES (Side Cutting)

1. Remove both set screws from each blade adapter, thread them into the opposite holes in the blade adapter perpendicular to the attachment pin, as shown in (Fig. 8), and repeat steps 1, 2, and 3 of above with the blade in the side cutting position.

Cutting from the side of the saw will be necessary when your work piece exceeds 16 inches in length. It allows the scroll saw to cut like a band saw.

FIG. 5

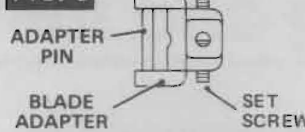

FIG. 6

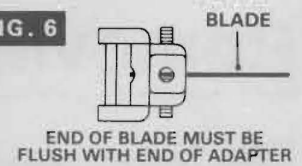

FIG. 7

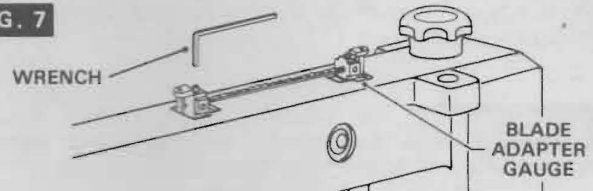
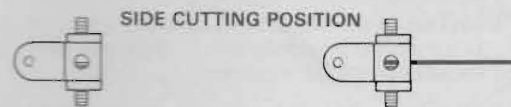

FIG. 8



WARNING

Do not attempt to cut a bevel with the blade positioned for side cutting.

REMOVING AND INSTALLING (Plain-End Blades)

1. Rotate the blade tension knob counter-clockwise to release blade tension (Fig. 9).
2. Remove table insert and remove blade from outer section of the upper and lower blade holders by pulling forward and lifting the blade and adapter through the access hole in the table. Slight downward pressure against the upper blade holder may be helpful when removing blade from upper blade holder.
3. Install the blade by inserting one end of the blade and adapter through the access hole in the table, and hooking the blade adapter onto the outer section of the lower blade holder. Slide top adapter onto pin recess between adapter guard and outer section of

4. In order to cut, and avoid uncontrollable lifting of the work piece, the teeth of the blade used on the scroll saw should always point downward when installed, as shown in (Fig. 9).
5. Carefully tighten the blade by rotating the blade tension knob clockwise just until you feel the slack in the blade removed. Double check to see that the adapters are properly positioned in the blade holder. Then turn the blade tension adjustment knob one full turn clockwise and then replace the table insert. This amount of pressure should do well for most cutting operations and blades.

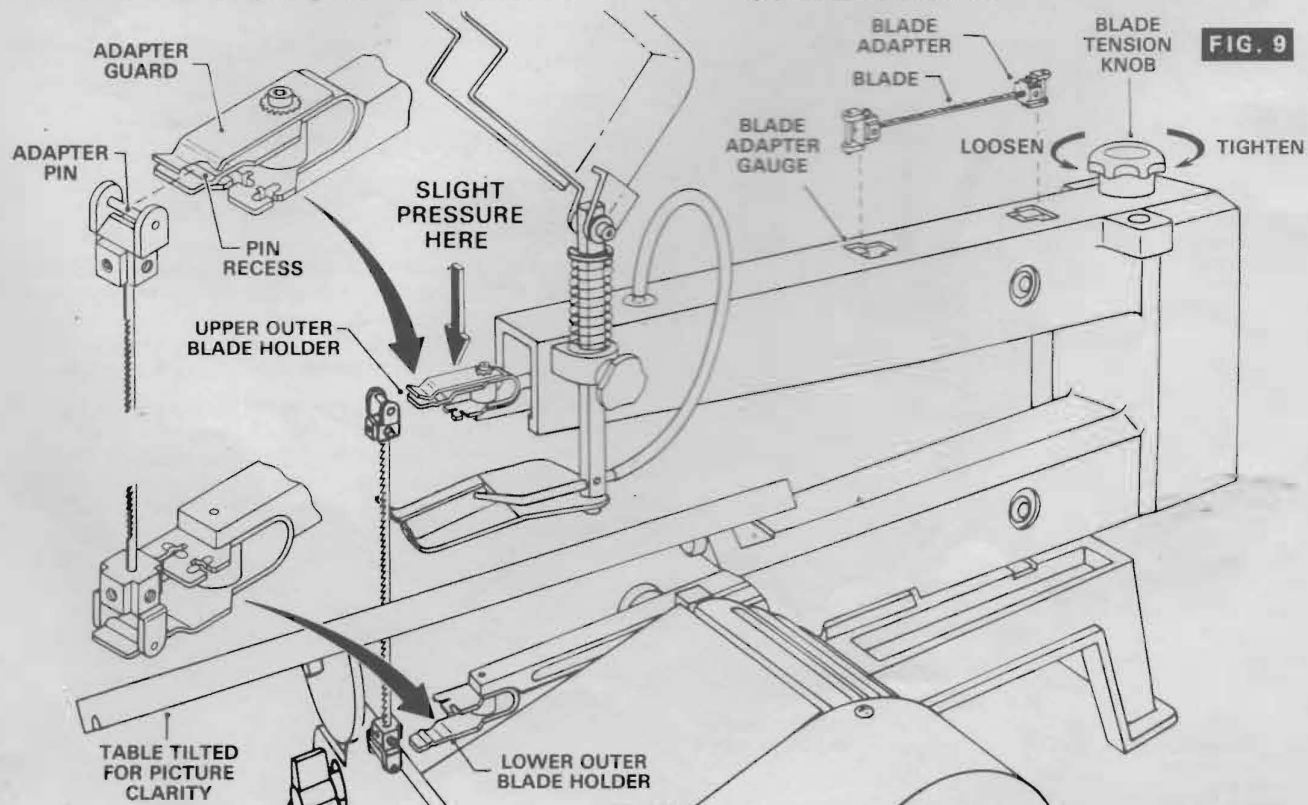

Mounting the scroll saw to a bench

1. When mounting this saw to a workbench, a solid bench is preferred over a plywood bench where noise and vibration will be more noticeable.
2. Hardware to mount this saw to a workbench is NOT SUPPLIED with the saw. However, we recommend the hardware used be no smaller than the following:

Quantity Description

- 4 Hex Head Screws, 1/4-20 Length Required
- 4 Flat Washers, 9/32 I.D.
- 4 Lockwasher, 9/32 I.D.
- 8 Hex Nuts, 1/4-20

3. Soft foam pad to place between your scroll saw and workbench is NOT supplied with the saw. However, we highly recommend the use of such a pad to reduce noise and vibration.

Quantity Description

- 1 Soft foam pad, such as carpet padding, 24" x 12" x 1/2"

Do NOT overtighten mounting bolts - leave some cushion in the foam pad for absorbing noise and vibration.

WARNING: Always remove the plug from power source before making any adjustments on your saw.

ATTENTION: When inserting the front right hex head screw, it will be necessary to remove 5 screws and remove the fan box cover.

4. Example of mounting this scroll saw to workbench:

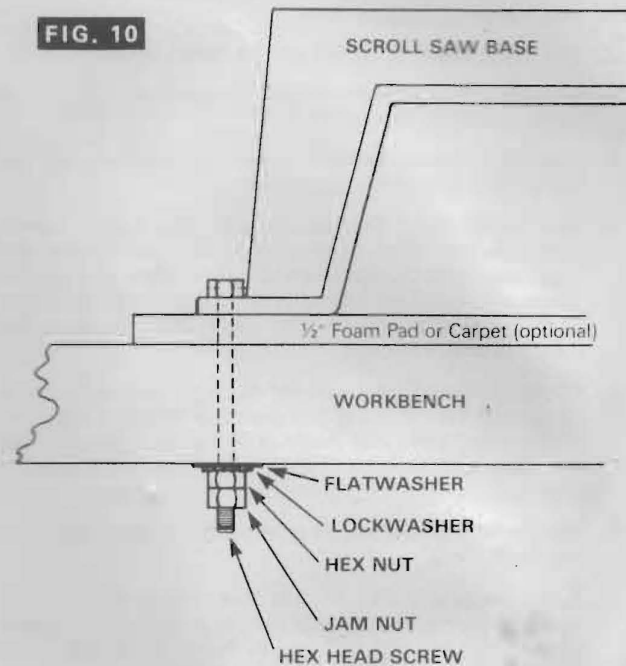

5. If you prefer to mount your saw to a leg set we recommend the leg set for bench top tools which is available through Dremel. The number of this leg set is 16435. This leg set is an optional accessory and instructions to mount the scroll saw to this leg set are included in the leg set package.

FIG. 11

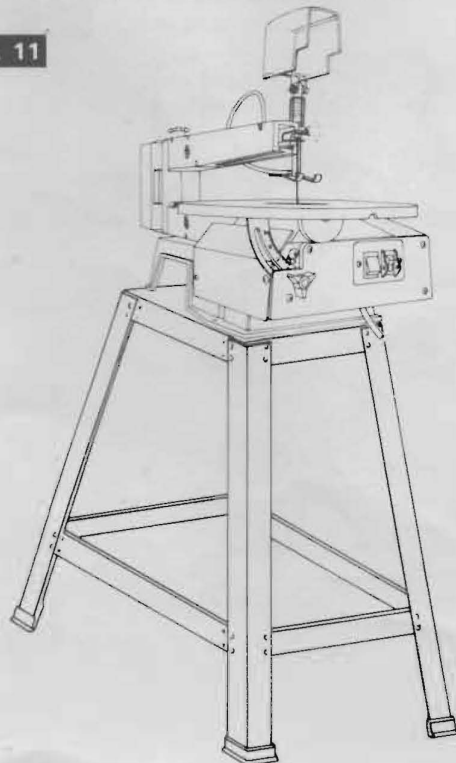

ATTACHING THE MAGNIFIER LAMP TO YOUR SCROLL SAW (Available as Accessory)
To install, simply insert round end of lamp base into the hole provided at the rear of saw as shown in (Fig. 12).

WARNING

Always be sure to position the cord away from cutting area.

FIG. 12

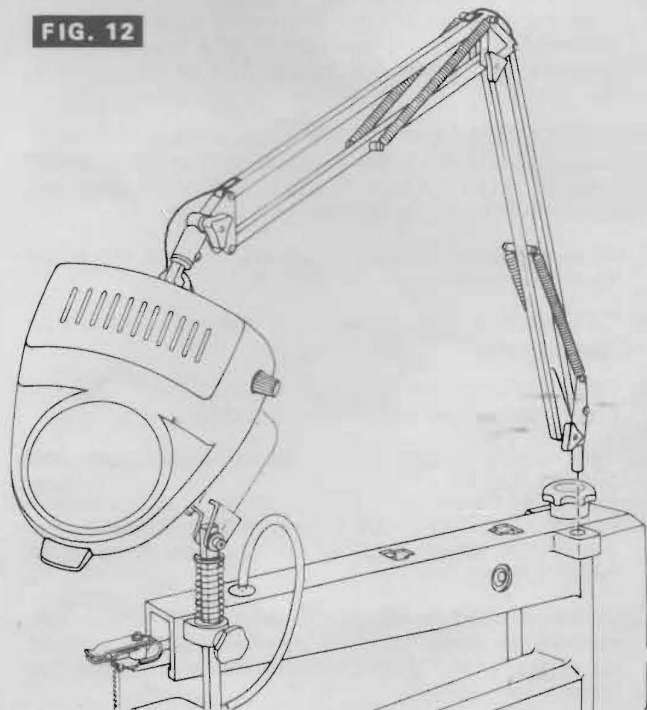

Operation

PLEASE, read and understand the following items about your scroll saw before attempting to use the saw.

1. The saw does not cut wood by itself. You allow the saw to cut wood by guiding the wood into the blade as it moves.
2. The blade teeth cut ONLY on the down stroke.
3. The drop foot should always be lowered until it just rests on top of the workpiece.
4. The blade guard should always be lowered over the blade during cutting operation.
5. You must feed the wood into the blade slowly because the teeth of the blade are very small and they can only remove wood when they are on the down stroke. The blade will flex backwards when applying feed pressure. Too much feed pressure will cause blade breakage.
6. There is a learning curve for each person who wants to use this saw. During that period of time it is expected that some blades will break until you learn how to use the saw and receive the greatest benefit from the blades.
7. Best results are achieved when cutting wood less than one inch thick.
8. When cutting wood thicker than one inch the user must feed the wood very slowly into the blade and take extra care not to bend or twist the blade while cutting in order to maximize blade life.
9. Teeth on the scroll blades wear out and as such must be replaced frequently for best cutting results. Scroll saw blades generally stay sharp for ½ hour to 2 hours of cutting.
10. To get accurate cuts be prepared to compensate for the blade's tendency to follow the wood grain as you are cutting.
11. When choosing a blade to use with your scroll saw consider the following carefully:
 - Very fine, narrow blades should be used to scroll cut in thin wood (¼ inch thick or less).
 - To cut wood over ¼ inch thick, use wider blades.
 - Most blade packages state the size or thickness of wood which that blade is intended to cut, and the radius (size of curve) which can be cut with that blade.
 - Wider blades can't cut curves as tight or small as thinner blades.
 - Narrower blades work well only on thinner wood material.
12. This saw uses 5 inch long, pin or plain-end type blades only (See Accessories on page 11).
13. Blades wear faster when cutting plywood, which is very abrasive; when sawing wood which is thicker than the ¾ inch blade stroke; and when sawing hardwood, or when side pressure is placed on the blade.
14. When cutting precious and non-ferrous metals, the blades must be used at very slow speeds. They perform well on machines that have variable speed capability and should be lubricated with beeswax, or a light machine oil.

MAKING INTERIOR SCROLL CUTS

1. One of the features of this saw is that it can be used to make scroll cuts on the interior of a board without breaking or cutting into the outline or perimeter of the board.

⚠ WARNING TO AVOID ACCIDENTAL STARTING, ALWAYS TURN SWITCH "OFF" AND REMOVE PLUG FROM POWER SOURCE BEFORE REMOVING OR REPLACING THE BLADE.

2. To make interior cuts in a board, remove the scroll blade as explained on pages 7 and 8.
3. Drill a ¼ inch hole in the board you will use to make interior cuts.
4. Place the board on the saw table with the hole in the board over the access hole in the table.
5. Insert blade through hole in board, install blade and adjust blade tension.
6. Lower drop foot until it just rests on top of the workpiece, lower blade guard and you're ready to begin cutting.
7. When finished making the interior scroll cuts simply remove the blade from the blade holders, as described on pages 7 and 8 and remove the board from the table.

FIG. 13



Scroll Saw Accessories

Leg Set

Cat No. 16435	Scroll Saw Stand
-------------------------	------------------

Portable Magnifier Lamp

Multi-purpose magnifier with adjustable arm and 39" reach. 40 watt incandescent bulb and 4" diameter, 3 diopter lens. Includes standard two-conductor cord set and 4-way mounting bracket. (black only)

Cat. No. 1304

Blade Adapter

Provides capability for changing back and forth between all sizes of plain end blades. Additional blade holders are recommended for quick change between blades.

Cat. No. 16436	Blade Adapter
--------------------------	---------------

Saw Blades

Dremel offers both plain and pin end 5 inch blades.

Pin end

Pin end blades are easier to take in and out of the machine.

Cat. No.	Purpose	Width	Thick	TPI	Speed
16411	For tight radius cutting in hard and soft wood.	.110	x .018	x 15	High/Low
16412		.110	x .018	x 10	High/Low
16413		.070	x .010	x 18.5 SK	High/Low

Plain end

The pin type blades, while somewhat easier to put in and take out of the machine, do not always produce the same controlled cutting action provided with the plain end blade. The 1671 Scroll Saw was designed to accept both.

Cat. No.	Purpose	Width	Thick	TPT	Speed
16440	For extremely tight radius cutting in wood, plastic and fibrous materials.	.022	x .010	x 28	High
16443		.029	x .012	x 20	High
16446		.038	x .016	x 12.5	High
16448		.045	x .017	x 11.5	High
16453		.062	x .020	x 9.5	High

Spiral

Saws in all directions without turning the work piece.

Cat. No.	Purpose	Kerf	TPI	Speed
16461	For wood, plastic and abrasive materials.	.028-.030	x 46	High/Low
16463		.034-.036	x 41	

Metal piercing

For cutting precious and non-ferrous metals; these must be used at very slow speeds. They perform well on machines that have variable speed capability and should be lubricated with beeswax, or a light machine oil.

Cat. No.	Purpose	Width	Thick	TPI	Speed
16479	Metals and other hardwood materials.	.024	x .012	x 48	Low
16483		.033	x .016	x 36	Low
16485		.041	x .019	x 30	Low

Maintenance Information

▲WARNING FOR YOUR OWN SAFETY, TURN SWITCH "OFF", AND REMOVE PLUG FROM POWER SOURCE BEFORE LUBRICATING OR DOING ANY MAINTENANCE ON YOUR SAW.

GENERAL

An occasional coat of paste wax on the work table will allow the wood being cut to glide smoothly across the work surface.

ARM BEARINGS

Lubricate the arm bearings with oil after 10 hours of use. Re-oil after every 50 hours of use or whenever there is a squeak coming from the bearings.

TO LUBRICATE

1. Turn saw on its side as shown in (Fig. 12).
2. Squirt a generous amount of SAE 20 oil around the shaft end and bronze bearing.
3. Let the oil soak in overnight in this condition.
4. Next day repeat the above procedure for the opposite side of the saw.

CAUTION:

Any servicing of this tool should be performed by an authorized service representative.

IMPORTANT! Use of any accessories or attachments other than those supplied by Dremel may be hazardous.

FIG. 14

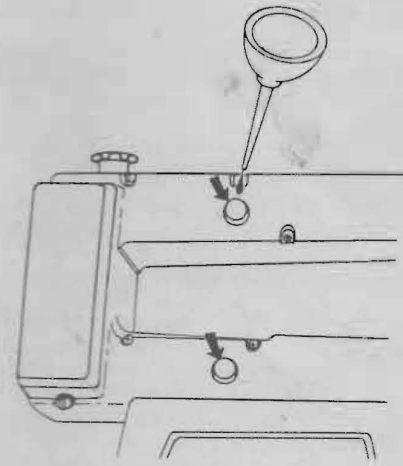

UNITED STATES

Dremel Service Centers, 4915 Twenty-first St., Racine, WI 53406, or 4631 E. Sunny Dunes Palm Springs, CA 92264.

CANADA

Giles Tool Agency 6520 Lawrence av. east Scarborough, Ont. Canada M1C 4A7, or Totem Tools 3851 Main st. Vancouver, B.C. Canada V5V 3P1.

Trouble Shooting

▲WARNING For your own safety, turn switch "OFF" and remove plug from power source outlet before trouble shooting.

TROUBLE	PROBABLE CAUSE	REMEDY SUGGESTED
BREAKING BLADES	<ol style="list-style-type: none"> 1. Wrong tension. 2. Over working blade. 3. Wrong blade application. 4. Twisting blade in wood. 5. Incorrect teeth per inch. 	<ol style="list-style-type: none"> 1. Adjust blade tension. 2. Reduce feed rate. 3. Use narrow blades for cutting thin wood, wide blades for thicker wood. 4. Avoid side pressure on blade. 5. Blade should have minimum 3 teeth in contact with workpiece.
MOTOR WILL NOT RUN	<ol style="list-style-type: none"> 1. Defective cord or plug. 2. Defective motor. 3. Defective wire connections. 	<ol style="list-style-type: none"> 1. Replace defective parts before using saw again. 2. Consult Dremel Service. Any attempt to repair this motor may create a HAZARD 3. unless repair is done by a qualified service technician.
VIBRATION NOTE: There will always be some vibration present when the saw is running because of motor operation.	<ol style="list-style-type: none"> 1. Improper mounting of saw. 2. Unsuitable mounting surface. 3. Loose table or table resting against motor. 4. Loose motor mounting. 	<ol style="list-style-type: none"> 1. See mounting instructions in this manual for proper mounting technique. 2. The heavier your work bench is, the less vibration will occur. A plywood workbench will not be as good a work surface as the same size solid lumber. Use common sense in choosing a mounting surface. 3. Tighten table lock knob. 4. Tighten mounting screws.
BLADE RUNOUT-Blade not in-line with arm motion	<ol style="list-style-type: none"> 1. Blade holders not aligned. 	<ol style="list-style-type: none"> 1. Loosen cap screws holding blade to arms. Adjust blade holders positions—retighten screws. (3.5mm allen wrench required).

DREMEL® MODEL 1671 TYPE 2 SCROLL SAW

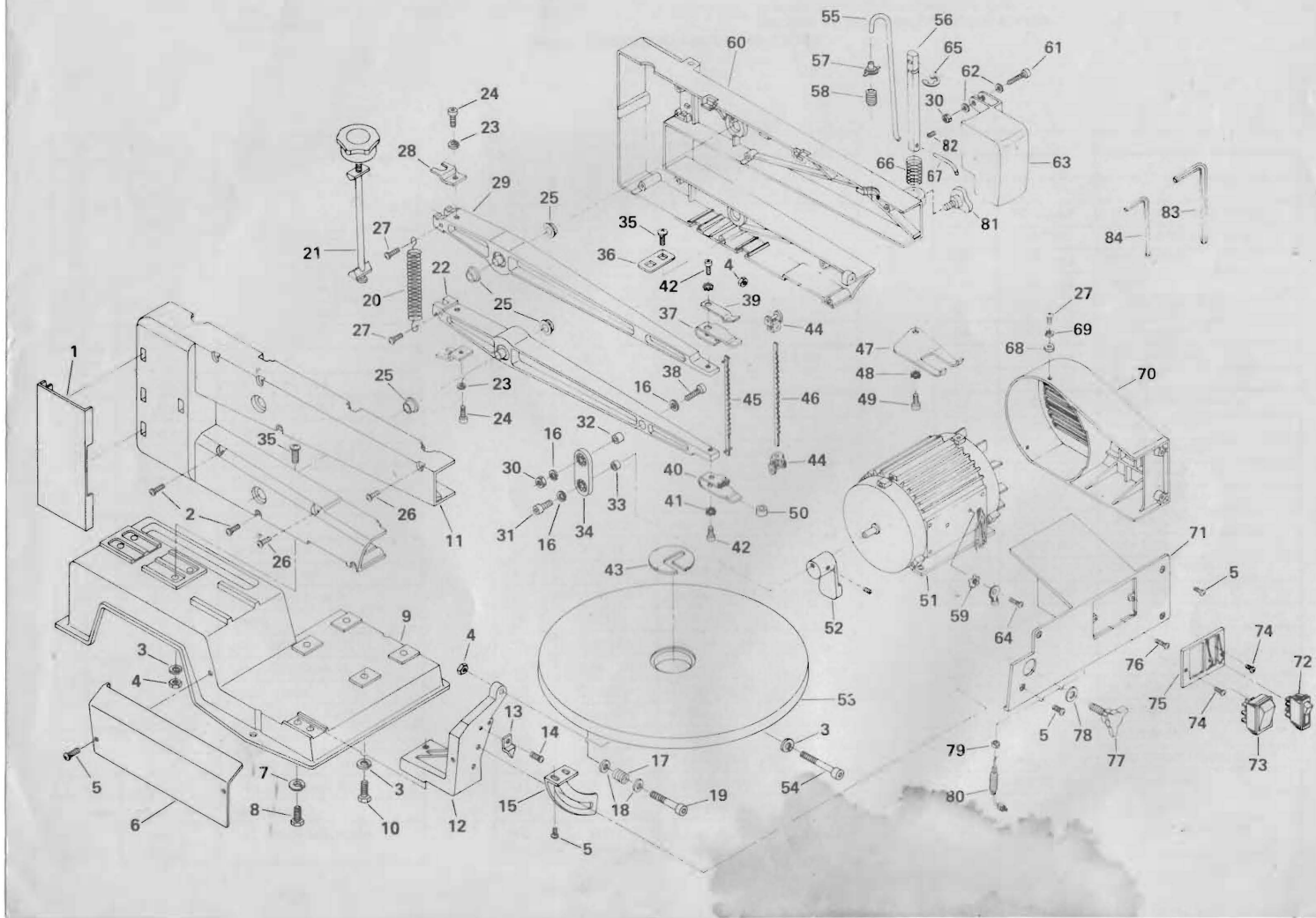

CODE NO.	PART NO.	DESCRIPTION
1	5296183	Blade Box
2	5296195	Self Tap Screw (8)
3	9730	Spring Washer (9)
4	11489	Hex Nut (6)
5	5296196	Pan Head Screw (8)
6	5296150	Plate Cover
7	44549	Spring Washer (2)
8	5296197	Hex Head Bolt (2)
9	5296182	Base
10	5870	Hex Head Bolt (4)
11	5296747	Housing Left
12	5296189	Supp. Table
13	5296177	Indicator
14	4775	Round Head Screw
15	5296154	Bracket Tilt
16	9709	Spring Washer (3)
17	5296165	Spring
18	67034	Flat Washer (2)
19	5296198	Hex Head Bolt
20	5296749	Spring
21	5296199	Bolt Tension
22	5296201	Lower Rocker Arm Assy.
23	1734	Spring Washer (2)
24	306064	Hex Head Bolt (2)
25	5296159	Bearing Flange (4)
26	5296202	Self Tap Screw (2)
27	5296217	Cap Head Screw (4)
28	5296164	Retainer (2)
29	5296213	Upper Rocker Arm Assy.

CODE NO.	PART NO.	DESCRIPTION
30	1309	Hex Nut (2)
31	306127	Hex Head Bolt
32	5296166	Spacer Bearing
33	5296167	Washer
34	5296203	Link Assembly
35	304837	Round Head Bolt (4)
36	5296179	Set Plate(2)
37	5296187	Holder Upper
38	313236	Hex Socket Bolt
39	5296508	Set Plate Upper Holder
40	5296186	Holder Lower
41	21599	Tooth Washer (2)
42	5296205	Hex Socket Head Bolt (2)
43	5296746	Table Insert
44	16436	Blade Adapter (2)
45		Blade (Pin Type)
46		Blade (Plain)
47	5296152	Guard Blade
48	26248	Tooth Washer
49	4721	Hex Socket Head Bolt
50	5296175	Bolt Collar (2)
51	5296194	Motor
52	5296210	Eccentric
53	5296191	Table
54	29359	Hex Socket Head Bolt
55	5296162	PVC Pipe
56	5296176	Support Rod
57	5296745	Bellows Lock
58	5296744	Bellows

CODE NO.	PART NO.	DESCRIPTION
59	5296247	Tooth Washer
60	5296748	Housing Right
61	313236	Hex Socket Head Bolt
62	29234	Washer (2)
63	5296184	Transparent Guard
64	5296207	Cap Head Screw
65	5296229	Retaining Ring
66	5296215	Spring
67	5296163	Brass Pipe
68	5296246	Flat Washer (2)
69	5296216	Spring Washer
70	5296185	Fan Box
71	5296190	Switch Case
72	5296218	On/Off Switch
73	5296219	Hi/Lo Switch
74	5296220	Self Tap Screw (2)
75	5296153	Switch Cover
76	5296221	Cap Head Screw (4)
77	5296172	Knob
78	26111	Flat Washer
79	5296222	Strain Relief
80	5296223	Power Supply Cord
81	5296242	Knob
82	5296243	Set Screw
83	5296244	Allen Wrench (4 mm)
84	5296245	Allen Wrench (2.5 mm)

WRITE FOR CURRENT PRICES - NO C.O.D.'S

UNITED STATES

Dremel Service Center, 4915 Twenty-first St., Racine, WI 53406
Dremel Service Center, 4631 E. Sunny Dunes, Palm Springs, CA 92262

EASTERN CANADA

Giles Tool Agency 6520 Lawrence av. east, Scarborough, Ont. Canada M1C 4A7

OUTSIDE OF CONTINENTAL UNITED STATES

See your local distributor or write to Dremel,
4915 Twenty-first St., Racine, WI 53406

WESTERN CANADA

Totem Tools 3851 Main st. Vancouver, B.C. Canada V5V 3P1

DREMEL
Form No. 5296679 4/91

4915 21st Street

RACINE, WISCONSIN 53406 U.S.A.
PRINTED IN U.S.A.

Unpacking and checking contents

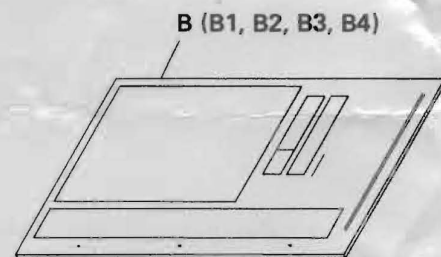
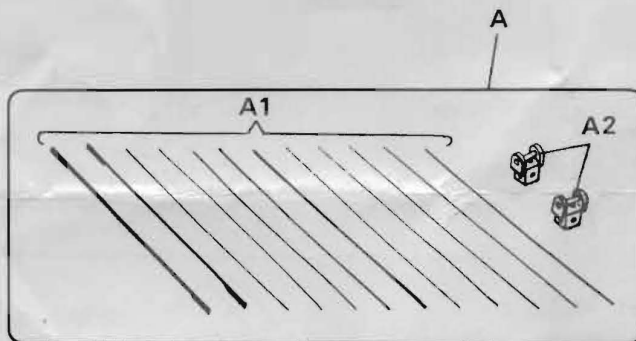
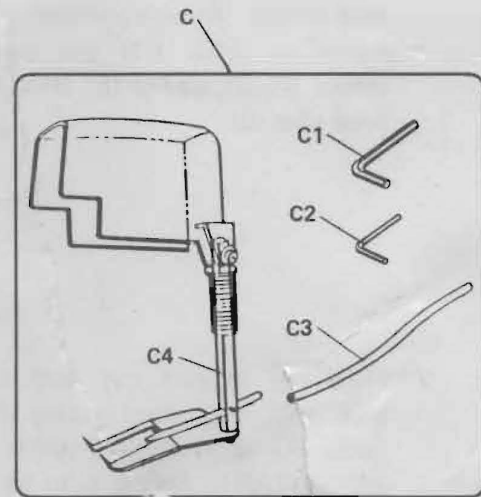
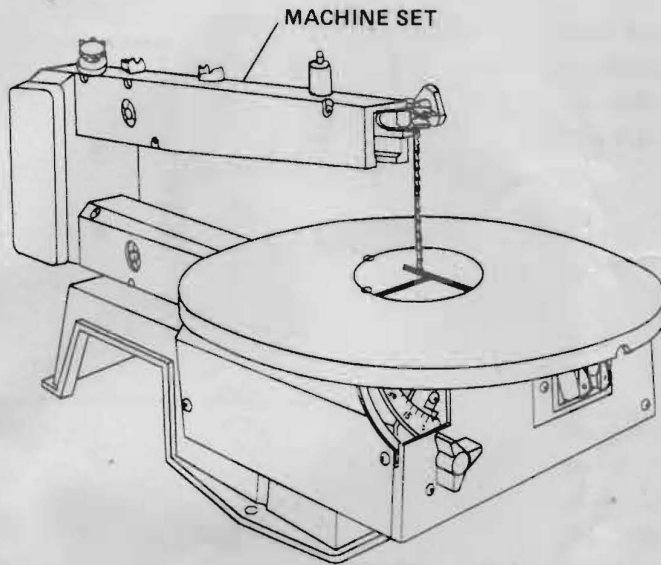

Model 1671 type 1 scroll saw is shipped complete in one carton. Separate all parts from packing materials and check each item with illustration and "TABLE OF LOOSE PARTS" make certain all items are accounted for before discarding any packing material.

If you have any problems with your saw, please call Dremel Customer Service before returning your saw to place of purchase. If Dremel can solve your problem on the phone, this will avoid inconvenience to you and shipping charges.

ITEM	TABLE OF LOOSE PARTS	Q'TY
A	Blades Bag Included:	
A1	Blades (1 Blade Installed on Machine) Total 13	12
A2	Blade Adaptors	2
B	Owner Manual Bag Included:	
B1	Owner Manual	1
B2	Bits of Info	1
B3	Reg. Card	1
B4	Parts List	1
C	Bag Assembly Included:	
C1	Allen Wrench (4mm)	1
C2	Allen Wrench (2.5mm)	1
C3	PVC Pipe	1
C4	Blade Guard Assembly	1

Installing blade guard assembly

1. Loosen the drop foot set scr. (C) and brass pipe set scr. (A) with provided allen wrenches shown in (FIG. 1-1) and remove the set screws (A, C), washer (E), drop foot (D) and brass pipe (B).

FIG. 1-1

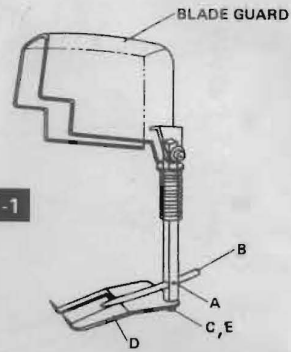

2. Place the support rod into it's mounting hole (FIG. 1-2), then locking it with screw knob (F) at available position (FIG. 1-3). **(IMPORTANT: Spring is to be installed for supporting guard assembly not to apply pressure to work surface)**

FIG. 1-2

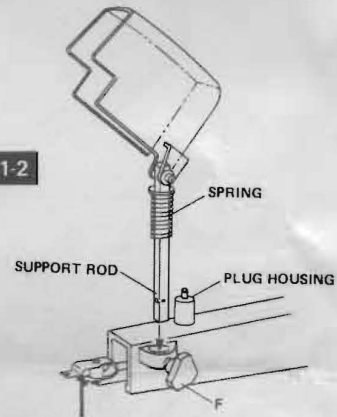

3. Insert brass pipe (B) and secured drop foot (D) into the support rod. Hand tighten their set screws and make sure the (B, D) position is correct. Then tighten the set screws with provided wrenches (FIG. 1-3). **(NOTE: After use the provided allen wrenches can be stored in the blade box on the side of the scroll saw).**

FIG. 1-3

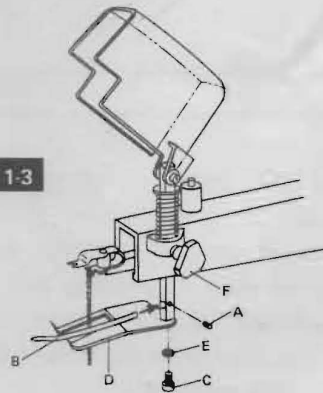

When mounting or relocating the saw dust blower nozzle, do not over tighten the set screw. Stop tightening when you feel resistance. Over tightening can damage the nozzle.

4. Insert the pvc pipe (H) one side end into the brass pipe (B) and plug housing (G) shown in (FIG. 1-4).

FIG. 1-4

